



INTERNATIONAL JOURNAL OF ADVANCE RESEARCH, IDEAS AND INNOVATIONS IN TECHNOLOGY

ISSN: 2454-132X

Impact Factor: 6.078

(Volume 9, Issue 2 - V9I2-1391)

Available online at: <https://www.ijariit.com>

Finite Element Approach for Beam-Column Joint Analysis in Reinforced Concrete Structure

Chintamani N.Khadake

chintamani.khadake@gmail.com

*JSPM Imperial College of Engineering
and Research, Pune, Maharashtra*

-----***-----

Abstract – *There are Different Methods have been used In Order to assess the behavior of Beams Columns with respect to Shear, Torsion, Buckling etc. of the Reinforced Concrete Structure. Generally the behaviors of these structure components are analyzed experimentally. With the Advanced progress in the numerical tools like Finite Element Method, it becomes easy to model and analyze the complex and detailed behavior of structural members like Beam, Column and Joints. In this present paper Model of Beam Column Joint subjected to axial and uniformly distributed loading are used. The Nonlinear Finite Element Analysis is used to analyze Beam Column Joint thoroughly with FEM software ANSYS.*

Key Words: Shear, Torsion, Buckling, Beam Column Joint, Nonlinear Finite Element Analysis, ANSYS.

1. INTRODUCTION

Beam column joints in a reinforced concrete moment resisting frame are crucial zones for transfer of loads effectively between the connecting elements (i.e. beams and columns) in the structure. The framed structures performance depends not only upon the individual structural elements but also upon the integrity of the joints. In most of the cases, joints of framed structures are subjected to the most critical loading under seismic conditions. Quite often the detailing of the joints is simply ignored. The failure of joints in reinforced concrete (RC) moment resisting frame structures may lead to collapse of the structural system as whole without adequate warning. Joints are the most critical because they ensure continuity of the members and transfer the forces at the ends of the members through them. A joint should maintain the integrity of the joining members and should be designed so that it is stronger than the members framing into it. So it should be designed and detailed properly. Experimental analysis is widely carried out to study individual component members, Joints but its time consuming and expensive.

Barbosa et al. [1] considered the practical application of nonlinear models in the analysis of reinforced concrete structures and the consequences of small changes in modeling. It was also concluded that the highest analysis loads could be considered as the ultimate loads of the models and the actual beams.

Revathi et al. [2] conducted finite element and experimental studies on under-reinforced, over-reinforced and shear test beams in ANSYS, to validate the potential of numerical simulation in predicting the nonlinear response of the elements. The numerical and test results were seen to compare well. The ductile behavior of under-reinforced beams and the brittle mode of failure in the over-reinforced and shear beams were produced well by the numerical model.

Prabhakara and Nambiyanna [3] carried out a study on the beam model with help of finite element method. They aimed to determine the effect of the diameter of longitudinal reinforcement of the beam on the parameters like strength, deformation and ductility in the beam-column joint using ANSYS. After analysis and result It was seen that the load carrying capacity and the deformation increases as the diameter of reinforcement in the beam increases.

Scott [4] have also analyzed and tested the beam column joint subjected to loading and then he performed studies by varying the parameters like reinforcement pattern using bent up, bent down and U-bars. After analysis and result, It was observed that the U-bars reinforcement show highest load carrying capacity than the bent up & bent down bars.

In this Paper the Beam Column Joint is of Nonlinear Material is modeled and analyzed using Finite Element Analysis Software ANSYS v17 is used to evaluate Total Elastic Strain, Elastic Stress and Total Deformation. The Material Models, Analysis Techniques and Elements are used with reference of Past researchers work which are validated by the results with experiments hence it need not to be validated again.

2. FINITE ELEMENT MODELLING

2.1 Element Types

Concrete :- The Solid65 element in FEM is used to model the concrete. This Concrete element has eight nodes with three degrees of freedom at each node and translations in the nodal x, y, and z directions. This element is capable of plastic deformation and cracking in three orthogonal directions, and crushing. A schematic of the element is shown in Fig- 1.

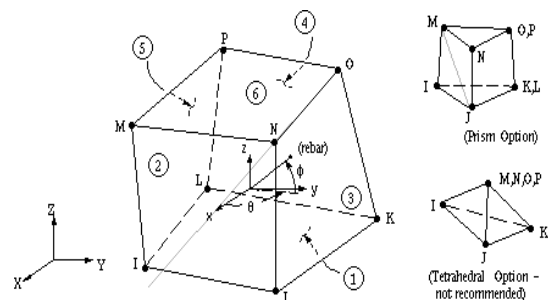

Fig -1: SOLID 65 Element

Link 8

LINK 8 is a spar, which may be used in a variety of engineering applications. Depending upon the applications, the element may be saw as truss element, a cable element, a reinforcing bar and a bolt. The three-dimensional spar element is having two nodes and each node having three translational degrees of freedom. This element is capable of plasticity, creep, swelling and stress stiffening effects. The cross sectional area can be given as the real constant. This element is shown in Fig 2.



Fig -2: LINK 8 Element

SOLID 45

SOLID 45 is a 3-dimensional brick element is used to model isotropic solid problems. It has eight nodes, with each node having three translational degrees of freedom in the nodal X, Y & Z directions. This element may used to analyze high deflection, high strain, plasticity and creep problems. It has no real constants. This element is illustrated in Fig 3.

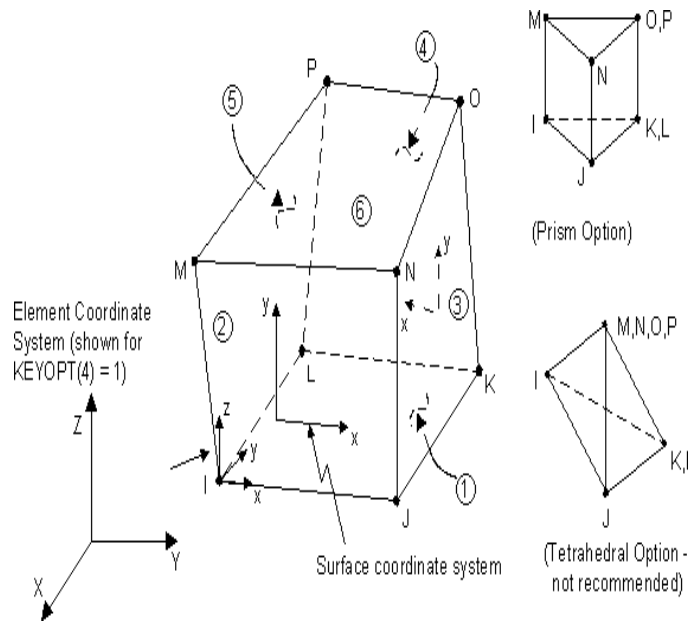

Fig -1: SOLID 45 Element

Material plays an important role in ANSYS modeling. Correct values of material properties have to be given as input in ANSYS. Cube compressive strength and Yield strength of reinforcing bars are found experimentally and these values are given as inputs. The challenging task in modeling the Beam -Column joints is the development of the behavior of concrete. Concrete is purely non-linear material and it has different behavior in compression and tension. The tensile strength of concrete is typically 8% to 15% of the compressive strength. Fig. 4 shows the typical stress-strain curve for normal weight concrete. In compression, the stress- strain curve of concrete is linearly elastic up to about 30% of LINK 8 is a spar, which may be used in a variety of engineering applications. Depending upon the applications, the element may be saw as truss element, a cable element, a reinforcing bar and a bolt. The three-dimensional spar element is having two nodes and each node having three translational degrees of freedom. This element is capable of plasticity, creep, swelling and stress stiffening effects. The cross sectional area can be given as the real constant. This element is shown in Fig 2.

Material plays an important role in ANSYS modeling. Correct values of material properties have to be given as input in ANSYS. Cube compressive strength and Yield strength of reinforcing bars are found experimentally and these values are given as inputs. The challenging task in modeling the Beam -Column joints is the development of the behavior of concrete. Concrete is purely non-linear material and it has different behavior in compression and tension. The tensile strength of concrete is typically 8% to 15% of the compressive strength. Fig. 4 shows the typical stress-strain curve for normal weight concrete. In compression, the stress- strain curve of concrete is linearly elastic up to about 30% of the maximum compressive strength. Above this point, the stress increases gradually up to the maximum compressive strength, and then descends into a softening region, and eventually crushing failure occurs at an ultimate strain ϵ_{cu} . In tension, the stress-strain curve for concrete is

approximately linearly elastic up to the maximum tensile strength. After this point, the concrete cracks and the strength decreases gradually to zero. ANSYS has its own non-linear material model for concrete. Its reinforced concrete model consists of a material model to predict the failure of brittle materials, applied to a three-dimensional solid element in which reinforcing bars may be included. The material is capable of cracking in tension and crushing in compression. It can also undergo plastic deformation and creep. Three different uniaxial materials, capable of tension and compression only, may be used as a smeared reinforcement, each one in any direction. Plastic behavior and creep can be considered in the reinforcing bars too.

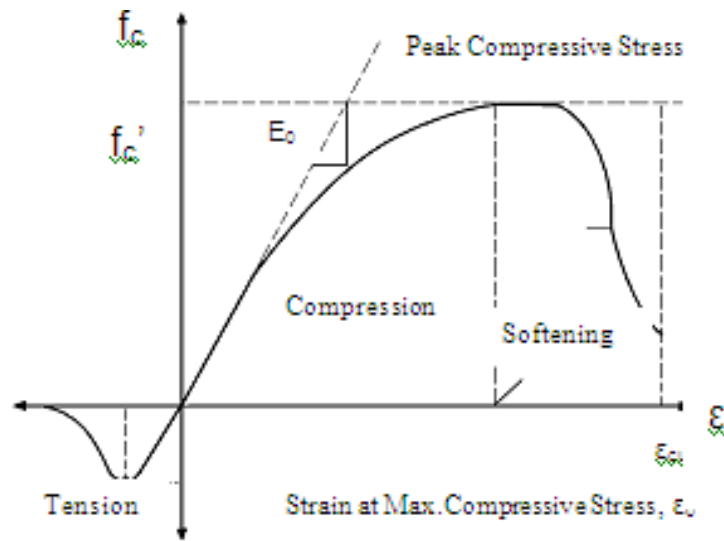
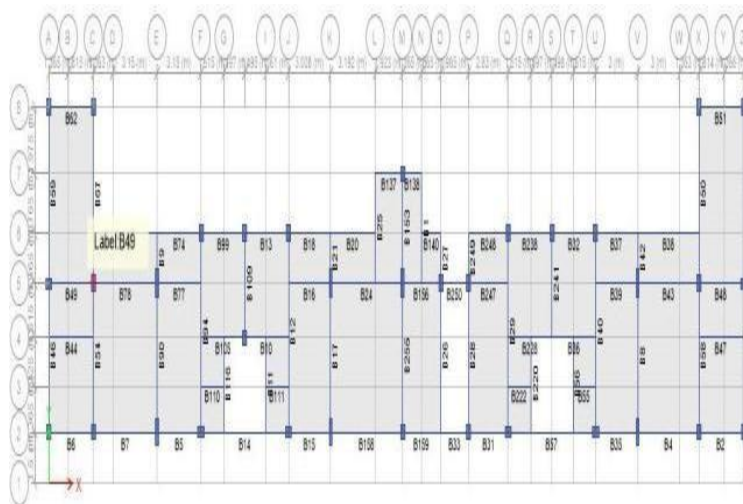

Fig -4: Stress –Strain Curve for Concrete

3. METHODOLOGY

Firstly to do analysis on Beam Column Joint the Reinforced Concrete Structure is modeled in the ETabs Software and proper Analysis is carried out on the structure, after analysis done the structure is designed according to forces and moments which we got from the analysis. And after the structure passes the design check, from that we select Exterior Beam Column Joint and analysis to be carried



out on that particular joint using ANSYS v17.1. The parametric study is analyzed by using software's like ETabs & ANSYS 17.1. The parametric study focuses on the analysis and design of the structure and after which analysis of exterior Beam Column joint carried out using FEM software.

Fig -5: Plan of Structure in ETabs

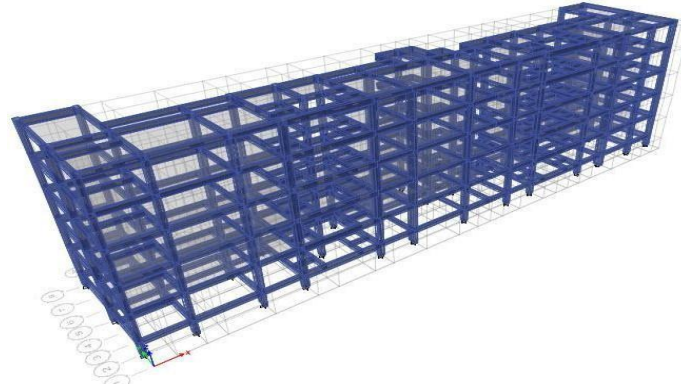

Fig -6: 3D View of Structure

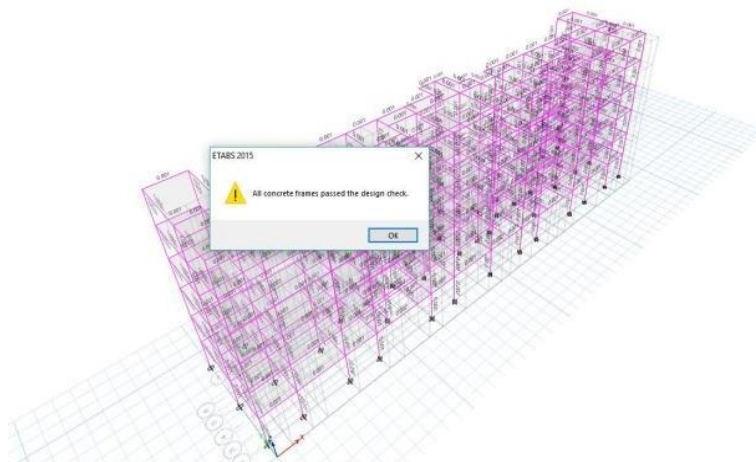

Fig -7: Design Check Passed

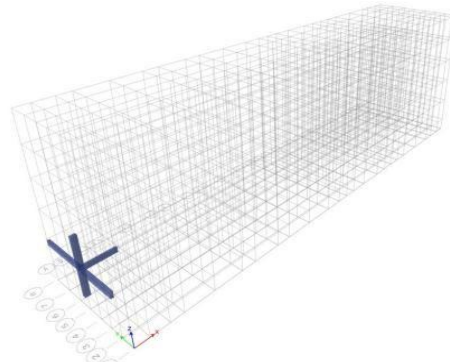

Fig -8: BC-Joint Selected for Analysis

Fig.5 and Fig.6 shows the plan of the structure and 3D View of the structure with Beam Column components. After analysis the structure gone for design check and Fig.7 shows the structure passed the design check. After passing design check one Exterior Beam Column Joint chosen for detailed analysis using Finite Element Method in ANSYS v17.

4. FINITE ELEMENT ANALYSIS OF BEAM COLUMN JOINT

4.1 Problem Statement

The BC-Joint selected from above structure is of second storey A5- which joints Beam no.B46, B49, B59 & Column C4. The Beam element has dimensions 300mm x 450mm & Column has Dimensions 450mm x 300mm.

Firstly the geometry of Beam Column Joint is modeled in ANSYS v17 software.

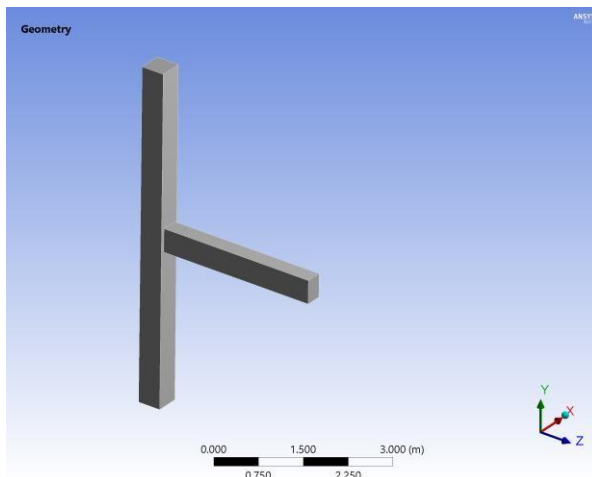

Fig -9: Geometry

Meshing:

After importing the model in ANSYS v17 and after giving proper properties the model is run for the Meshing. Following fig.10 shows the Meshed model of Beam-Column Joint.

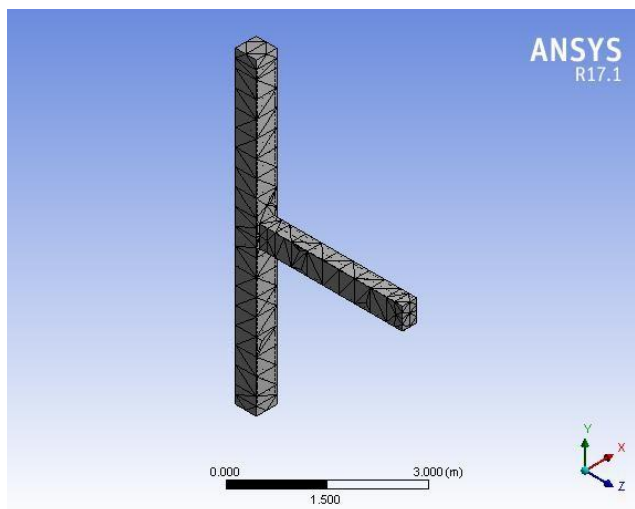

Fig -9: Geometry

Loading

fig.11 shows the loaded model of Beam-Column Joint with Axial Column load & Uniformly Distributed load on beam portion.

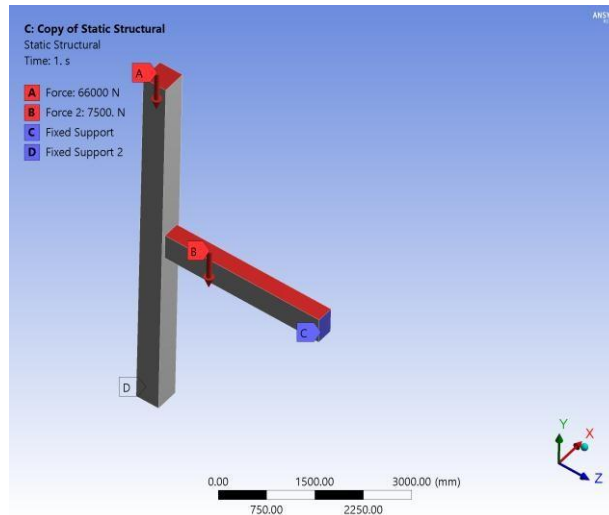

Fig -11: Loading applied on BC-Joint

4.2 Results and Discussion

After loading applied the model is gone through analysis and got following results.

4.2.1 Total Deformation

The Total Deformation obtained is tabulated in the Table.1 with the values and according to fig.12 the Joint shows safer values.

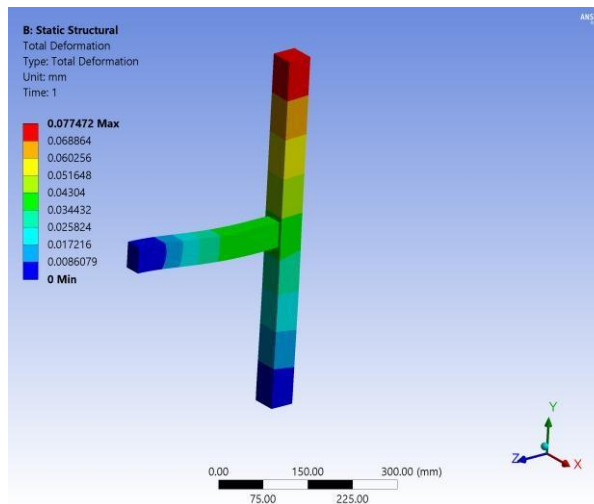

Fig -12: Total Deformation

Table -1: Total Deformation

Time [s]	Minimum [mm]	Maximum [mm]
1.	0.	7.7472e-002

4.2.2 Equivalent Elastic Strain

The Equivalent Elastic Strain obtained is tabulated in the Table.2 with the values and according to fig.13 the Joint shows safer values.

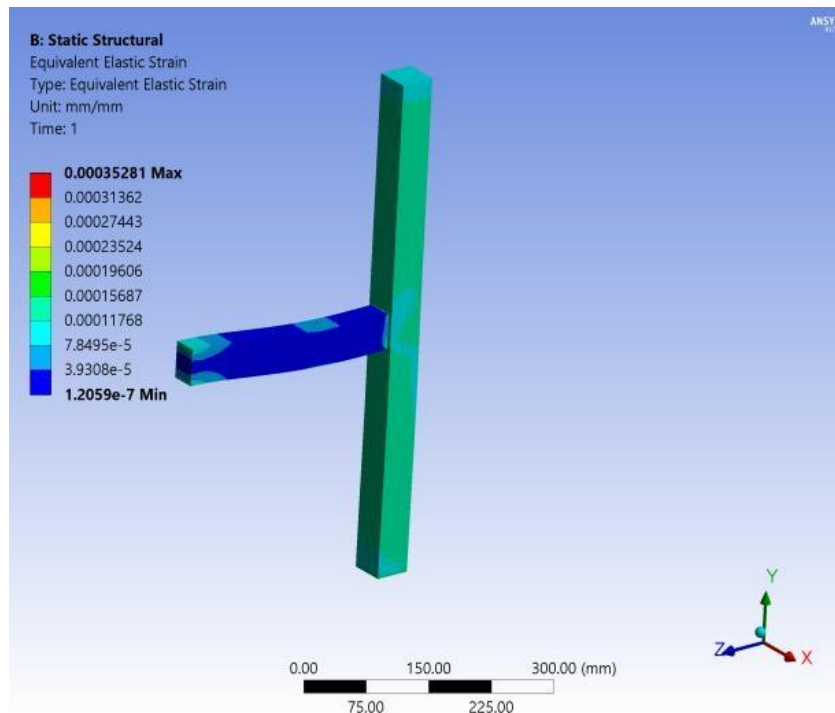

Fig -13: Equivalent Elastic Strain

Table -2: Equivalent Elastic Strain

Time [s]	Minimum [mm/mm]	Maximum [mm/mm]
1.	1.2059e-007	3.5281e-004

4.2.3 Equivalent Stress

The Equivalent Stress obtained is tabulated in the Table.3 with the values and according to fig.14 the Joint shows safer values.

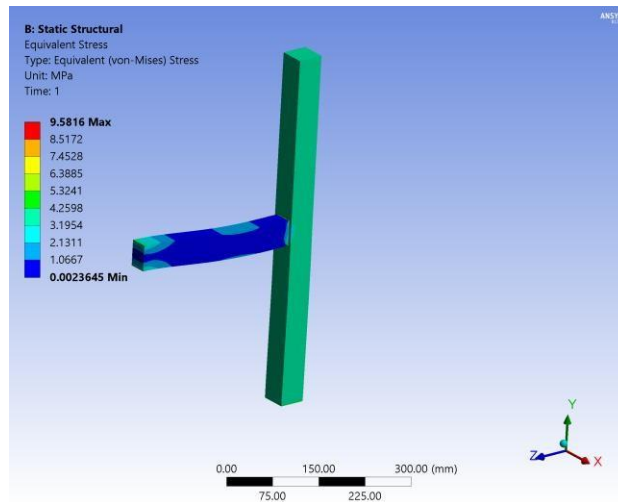

Fig -14: Equivalent Stress

Table -3: Equivalent Stress

Time [s]	Minimum [MPa]	Maximum [MPa]
1.	2.3645e-003	9.5816

As we see the results and distribution of stress , the maximum stress comes out as 9.5816 and the minimum stress value comes as 2.364e-003. Also as we see the strain distribution the maximum strain value comes out as 3.5281e-004 and minimum value comes out as 1.2059e-007. As we see the result diagram it is seen that the stress and strain comes on the beam column joint is very less and it is safe against cracking.

CONCLUSIONS

The study was aimed to do the analysis of the reinforced concrete structure by estimating forces and based on these forces the design is to be carried out, After that study focused on the use of Finite Element Analysis to observe behavior of External Beam Column Joint. Further it was aimed to perform detail analysis of Beam Column Joint in FEA Software to analyze the stress, strain distribution pattern. By study of Finite Element Analysis, it is observed that computer simulation offers proper potential to understand the behavior of beam column joint under various loading. Detailed analysis is performed for Beam Column Joint for stability of joint under consideration, and according to Fig.no.12 which shows Total Deformation Maximum value is 7.7472e-002 which is very low , Also Fig.no.13 shows Total strain values Minimum value 1.2059e-007 and maximum value 3.5281e-004 which is within limits and Fig.no.14 shows stress distribution results Minimum value 2.3645e-003 & Maximum value 9.5816 which shows that the values are within limits and the joint is safe.

ACKNOWLEDGEMENT

This work is supported by all experienced staff and Civil Engineering Department of College of Engineering Pandharpur, Maharashtra, India, for providing us valuable guidance and ANSYS 17.0

REFERENCES

- [1] Antonio F. Barbosa and Gabriel O. Ribeiro, "Analysis Of Reinforced Concrete Structures Using Ansys Nonlinear Concrete Model", Computational Mechanics, New Trends And Applications, Barcelona, Spain (1998).
- [2] P. Revathi and DevdasMenon, "Nonlinear finite element analysis of reinforced concrete beams", Journal of Structural Engineering (2005).
- [3] R Prabhakara, Harish R, Nambiyanna B, "Analytical investigation of external beam column joint using ANSYS by varying the diameter of the longitudinal reinforcement in beam", Journal of engineering science and technology Volume 5,issue 8, part -1. (2015)
- [4] Scott R.H, "The Effect of Detailing on RC beam column connection Behavior", The structural engineer, Volume 70.(1992)
- [5] Subramanian, N. and Rao, D.S.P., "Seismic Design of Joints in RC Structures –A Review", Indian Concrete Journal, Vol.77, No.2. (2003).
- [6] Thomas H KKang and Mitra, "Prediction and Performance of Exterior beam column connections with headed bars subjected to load reversal", Journal of Engineering Structures, issue 4, (2012).
- [7] AnusreeLal, " Analysis of Exterior Beam Column Joint Using ANSYS, International Journal of Science and Research, Volume 5,Issue 7. (2016).
- [8] IS 13920:1993, "Ductile Detailing of Reinforced Concrete Structure Subjected to Seismic forces-code of Practice", Bureau of Indian Standards, New Delhi.
- [9] IS 456:2000, "Indian Standard Plain and Reinforced Concrete Code of Practice (Fourth Revision)", Bureau of Indian Standards, New Delhi.