



# INTERNATIONAL JOURNAL OF ADVANCE RESEARCH, IDEAS AND INNOVATIONS IN TECHNOLOGY

ISSN: 2454-132X

Impact Factor: 6.078

(Volume 7, Issue 3 - V7I3-1701)

Available online at: <https://www.ijariit.com>

## Helmet Safety using IoT

Pushpak Goswami

[pushpakgoswami645@gmail.com](mailto:pushpakgoswami645@gmail.com)

Anjuman College of Engineering and  
Technology, Nagpur, Maharashtra

Fardeen Sheikh

[fardeensheikh100@gmail.com](mailto:fardeensheikh100@gmail.com)

Anjuman College of Engineering and  
Technology, Nagpur, Maharashtra

Smit Ramteke

[aryanakul0526@gmail.com](mailto:aryanakul0526@gmail.com)

Anjuman College of Engineering and  
Technology, Nagpur, Maharashtra

Rohish Zade

[rohishz@yahoo.com](mailto:rohishz@yahoo.com)

Anjuman College of Engineering and  
Technology, Nagpur, Maharashtra

Sumesh Chaure

[sumeshchaure1999@gmail.com](mailto:sumeshchaure1999@gmail.com)

Anjuman College of Engineering and  
Technology, Nagpur, Maharashtra

### ABSTRACT

*The most common prey of a road accident is a person who is having a two-wheeler vehicle and the persons who lost their lives in these accidents are the ones who don't wear helmets. There are many laws made but the result is null and void. To lessen the number of death and to make an efficient system, we have come up with the idea that if you will not wear a helmet you are unable to start your vehicle.*

**Keywords**— Helmet, Two-wheeler, E-vehicle.

### 1. INTRODUCTION

When a motorcyclist and two-wheeler riders are involved in a high-speed collision without wearing a helmet, the impact is extremely harmful and can result in death. Wearing a helmet can reduce shock from the impact and may save a life. There are many countries enforcing a regulation that requires the motorcycle and two-wheeler rider to wear a helmet when riding on their motorcycle[2]. The most common prey of road accidents are two-wheeler drivers and they are most prone to death as they are avoiding wearing helmets. As we are from India, there are some shocking facts that 60 percent of the Indian population travel with two-wheelers, and out of which only 5-10 percent wear a helmet only for the fear of getting fined. The solution to this problem is not that difficult you will get to know about it in a further part of this research paper.

### 2. LITERATURE REVIEW

#### 2.1 Existing system

The current system that is used in India is the challan system. In which if a person doesn't wear helmet and traffic police caught him/her. Then he/she has to pay the fines for not wearing helmets.

#### 2.2 Research work

There are some researches done on helmet safety and some intelligent brains have designed a smart helmet which has more advanced features as if you had an accident then there is some system involved in it that will send a message or call both to hospitals and police station as well as it detects your face through camera then only your vehicle will start[1]. This is not any system as it is very expensive as still those minds are working on it.

#### 2.3 Advantages of existing system

- The number of people wearing a helmet has increased
- Accident deaths due to head injuries are reduced by 2-3%

#### 2.4 Disadvantages of existing system

- Traffic police are not available everywhere.
- People are still not wearing helmets: There are various reasons for it
- Some underage children don't wear helmets as they are always in a hurry, they are unaware of traffic rules and the importance of wearing helmets.
- Some two-wheeler drivers don't wear a helmet and if they are caught by the traffic police, they encourage the traffic police to take bribes.

### 3. PROPOSED SYSTEM

**Problem Statement:** The issue is that individuals do not wear helmets when riding two-wheelers.

**Solution:** If the person is not wearing a helmet then the person is unable to start the two-wheeler vehicle. Now, the question arises how does it work? So, the main parts of the setup consist of an IR sensor, Relay, Transmitter and receiver, the Bolt Wi-Fi module, and 2 Arduino Uno. More details are given in the system requirements.

For better understanding, we have divided our project into three modules

**Module 1: Circuit present on helmet**

One Arduino Uno is placed on the helmet and with the help of jumping wires, transmitter, and IR sensor are connected to it the IR sensor is inside the helmet which examines if there is an item inside its range or not on a regular basis.

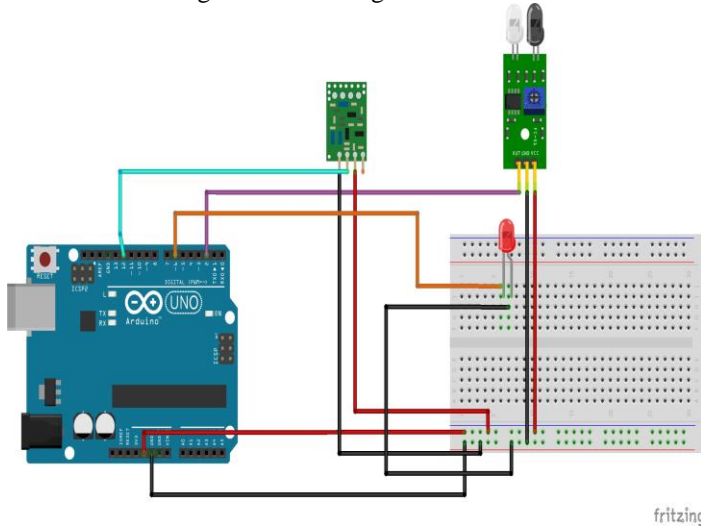

**Fig 1.1(a) Helmet Circuit**

**Module 2: Circuit present inside the vehicle**

Another Arduino Uno is placed near the battery of 2 wheeled vehicles along with jumper wires, relay module, receiver module, IR sensor, and bolt Wi-Fi module are connected to it, Relay module is connected to battery and Arduino.

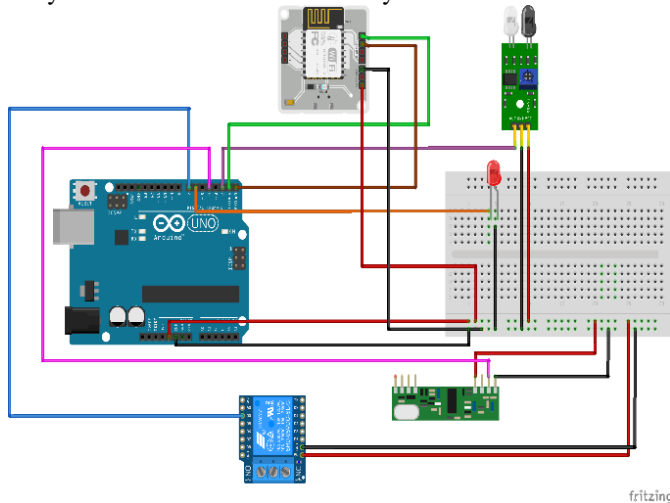

**Fig 1.1(b) Vehicle Circuit**

**Module3:Python script**

Basically, python script is used to run the program to send the SMS to the user.

**4. WORKING**

When a person is not wearing a helmet, the IR sensor outputs the value "0," which is then transmitted via the transmitter, and then the receiver will catch thus relay will disconnect the circuit and there is one IR sensor in the vehicle circuit which detects the handle moment if the person is not wearing a helmet it sends the SMS through Twilio service, hence, the relay has disconnected the circuit so, the person will not able to "Self-start" the vehicle.

Whereas when the person wears the helmet also IR sensor detects it, the "1" value is transmitted from the transmitter which is received by the receiver and the IR sensor present

inside the vehicle that checks the handle moment will be disabled and the relay establish the connection and vehicle is started when self-start button is pressed.

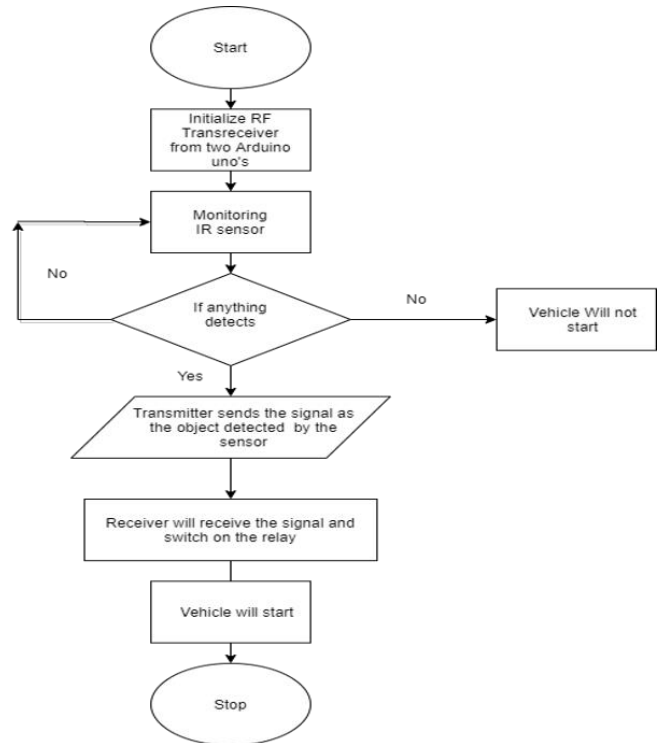

**Fig 1.1(c) Flow chart**

**4.1 Advantages of proposed system**

- 1) Better than the Challan system
- 2) Reduce the Death Rate
- 3) Enforcing to wear a helmet

**4.2 Disadvantages of proposed system**

- 1) IR sensor: As IR sensors can detect any object not necessarily the head. This problem can be resolved by using EEG Sensors.

**5. HARDWARE REQUIREMENTS**

- 1) Arduino Uno
- 2) IR sensor
- 3) Bolt Wi-Fi Module
- 4) RF transceiver module
- 5) Jumper wires
- 6) Bread Board
- 7) Battery
- 8) Relay Module

**6. SOFTWARE REQUIREMENTS**

- 1) Bolt Cloud
- 2) Ubuntu Server
- 3) Arduino IDE
- 4) Twilio SMS Service

**7. SCOPE OF THE PROJECT**

This system is highly efficient in two-wheeler electric vehicles.

**8. CONCLUSION**

The conclusion is that this system will enforce the vehicle driver to wear the helmet unless the vehicle driver is not wearing the helmet the vehicle will not start and as it is an automated system and does not involve any human intervention there is no bias-ness that who should wear the helmet and who should not. This system is also cost- efficient and in the future can come preinstalled with the E-vehicles.

**9. REFERENCES**

- [1] Kenleigh C Hobby, Brendan Gowing, and David P Matt. Smart helmet, July 12 2016. US Patent 9,389,677.  
[2] Mohd Khairul Afiq Mohd Rasli, Nina Korlina Madzhi, and

Juliana Johari. Smart helmet with sensors for accident prevention. In *2013 International Conference on Electrical, Electronics and System Engineering (ICEESE)*, pages 21–26. IEEE, 2013.