



INTERNATIONAL JOURNAL OF ADVANCE RESEARCH, IDEAS AND INNOVATIONS IN TECHNOLOGY

ISSN: 2454-132X

Impact Factor: 6.078

(Volume 7, Issue 2 - V7I2-1341)

Available online at: <https://www.ijariit.com>

Design and analysis of an In-Pipe Inspection Robot

Deepak Sonawane

deepaksonawane174@nhitm.ac.in

New Horizon Institute of Technology and Management,
Thane, Maharashtra

Omkar Baile

omkarbaile174@nhitm.ac.in

New Horizon Institute of Technology and Management,
Thane, Maharashtra

Samadhan Bhosle

samadhanbhosale174@nhitm.ac.in

New Horizon Institute of Technology and Management, Thane,
Maharashtra

Omswarup Kotkar

omswarupkotkar174@nhitm.ac.in

New Horizon Institute of Technology and Management, Thane,
Maharashtra

ABSTRACT

Previously there are various designs available regarding of an in-pipe inspection robot. This research paper aims at preparing a new design along with its Analysis. In a beginning we studied the available designs and Analysis reports. We have used SOLIDWORKS to design and Analysis of our robot. Our model is a wireless in-pipe inspection robot which is efficient to pass through a pipe with diameter in range of 170-200mm. The important areas we have considered while in the process of design are strength, safety while performing task, steer ability, and the most important one is size and shape adjustability We can detect various defects such as cracks, corrosion, blockages, material decay, flaws etc.

Keywords: *In-Pipe Inspection, Strength, Shape Adjustability, Wireless, Design, Analysis*

1. INTRODUCTION

Robotics is one of the fastest growing engineering fields of today. Robots are designed to remove the human factor from labor intensive work. The main concept behind the making of an in-pipe inspection robot is to lower the cost of labour and increase safety and accuracy in inspection. We did design and analysis of robot considering the complexity in pipes used in various power plants. Our robot can adapt itself according to the varying pipe diameter ranging from 170-200mm. The oil, steam and water distribution pipelines as well as heavy industrial plants require routine inspection. We have used single joint locomotive system so that our robot can pass through horizontal and incline pipes. The microcontroller is used for making robot fully autonomous. The Wireless camera is mounted at the front side of the assembly which can cover front area of the pipe. The result of camera is given through the receiver connected to LED screen. The range of camera receiver is approximately 25m while that of the remote is 8m.

2. LITERATURE REVIEW

From the research paper of Jong-Hoon Kim, Gokarna Sharma, and S. Sitharama Iyengar have proposed the design and implementation of a single module fully autonomous mobile pipeline exploration robot, called FAMPER that can be used for the inspection of 150mm pipelines. This robot consists of four wall-press caterpillars operated by two DC motors each. The speed of each caterpillar is controlled independently to provide steering capability to go through 45-degree elbows, 90-degree elbows, T-branches, and Y branches. The uniqueness of this paper is to show the opportunity of using 4 caterpillar configuration of superior performance in all types of complex networks of pipelines. The robot system has been developed and experimented in different pipeline layout. This robot also has wide applications in chemical industries as well as in gulf countries for inspection of oil and gas pipelines[1]. From the research paper of Atul Gargade¹, Dhanraj Tambuskar, Gajanan Thokal have proposed that robot consists of a foreleg system, a rear leg system, and a body. The fore and rear leg systems are constructed by using three worm gear system that is arranged at an angle of 120 degrees with respect to each other to operate inside a pipe of different diameters. The springs are attached to each leg and the robot body to operate in pipes of 140mm to 200mm diameter range. [2] The research paper of palwinder Kaur¹, Ravinder Kaur, Gurpreet Singh have worked on innovative concept to handle the bore well rescue operations without human intervention and to inspect any type of leakage in the pipe. Wheeled leg mechanism is employed in this design to go inside the pipe. The legs are circumferentially and symmetrically spaced out 120° apart. The robot is made adaptive so that it can adjust its legs according to the pipeline dimensions. This structural design makes it possible to have the adaptation to the diameter of the pipe and to have adjustable attractive force towards the walls of the pipe.[3] Nur Afiqah Binti Haji Yahya, Negin Ashrafi, Ali Hussein Humod have explained the robotics application in various industries mainly in pipeline inspection. This review paper was to fulfill the requirement of Automation and Robotics module assessment. The objectives of this review

paper are; to observe different robotics applications in pipelines inspection, to learn the different design of robots in pipeline inspection, to outline the problems and adaptability improvements in the robotics application that was applied. At the end of this review paper, it was concluded that improvements were seen in few designs of the robot example like the Parallelogram Wheel Leg [4]. proposes a hybrid locomotion system for inspection. The research paper of Xin Li [5], proposes guarding algorithm along with optimal guarding algorithm.

3. MECHANISM

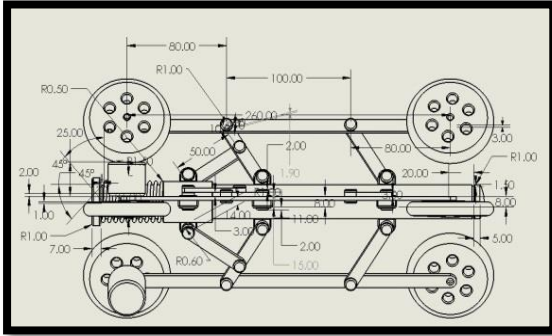

Fig. 1: Mechanism

Designs

A. Motor

Total load on robot = 50N (approx.)
 Power required to robot to carry weight of 50N with 0.1m/s speed is,

$$P = W \times v$$

$$P = 50 \times 0.1$$

$$P = 5 \text{ watts}$$

In worst case if only one motor is working then it has to give total power. Power required to 3-DC motors to drive the robot is,

$$P_{\text{required}} = 5 \times 2 \quad P_{\text{required}} = 10 \text{ watts}$$

If a motor of 12V & 1amp current is selected then power provided by 3 motors is,

$$P_{\text{provided}} = 30 \text{ watts}$$

Here,

$$P_{\text{provided}} > P_{\text{required}}$$

Hence ok.

So, select 3-DC motors of 12v, 1amp current.

B. Compression Spring.

D = 30mm diameter, L = 50mm, d = 2.5 diameter, Pitch = 5mm, FOS = 5.

Material :- Plain Carbon steel in Analysis and we selected C-45 from PSG data book.

Permissible Stress :- 104 N/mm². Yield Stress :- 360 N/mm².
 Spring force calculation :-

In vertical case, total load acting on robot is additional sum of weight of robot and frictional force i.e. 40.689N.

∴ we have to design a spring which will hold the load of

40.689N

∴ Design the spring for 40.689N force. Calculation of spring stiffness (K):

Spring stiffness = spring force / maximum elongation of spring

$$K = 40.689/22.5 ; K = 1.80.$$

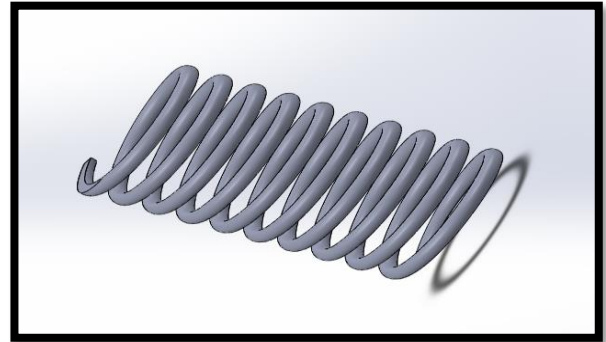

Fig. 2: Spring

C. Links (A,B1,B2,C)

For Robot we want total 12 links. Out of 12 links 3 are link A which has dimension L = 260mm, H = 10mm. Another 3 links are link B1 which has dimension L = 55mm, H = 10mm.

Another 3 links are links B2 which has dimension L = 55mm, H = 10mm. Another 3 links are link C which has dimension L = 50mm, H = 10mm, and all links have thickness about 3mm and hole of diameter about 6mm.

Materials :- We use Aluminium in Analysis and we selected C-25 from PSG data book.

Permissible Stress :- 163 N/mm². Yield Stress :- 280 N/mm². Total force on links at outside i.e. link A is approximate 14N. Only bending occurs on links for that we find bending stress,

$$\frac{M}{I} = \frac{\sigma_b}{y}$$

$$\frac{560}{\frac{bh^3}{12}} = \frac{\sigma_b}{\frac{10}{2}}$$

$$\frac{560}{\frac{3 \times 10^3}{12}} = \frac{\sigma_b}{5}$$

$$\sigma_b = 11.2 \text{ N} / \text{mm}^2.$$

$$\sigma_b = 11.2 < 163 \text{ N} / \text{mm}^2. \text{ ----(Hence Safe.)}$$

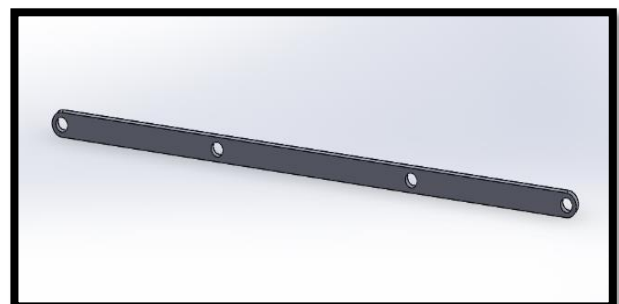

Fig. 3: Link A

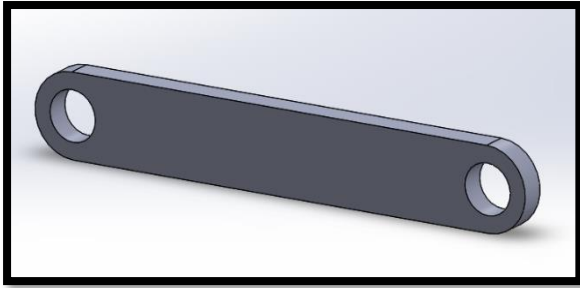

Fig. 4: Link B1

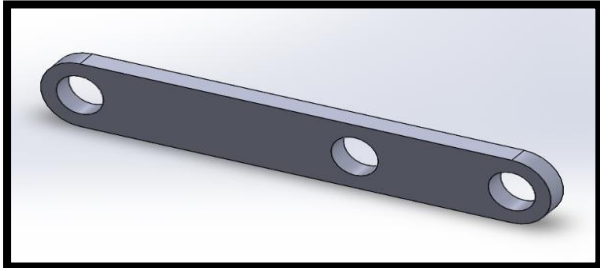

Fig. 5: Link B2

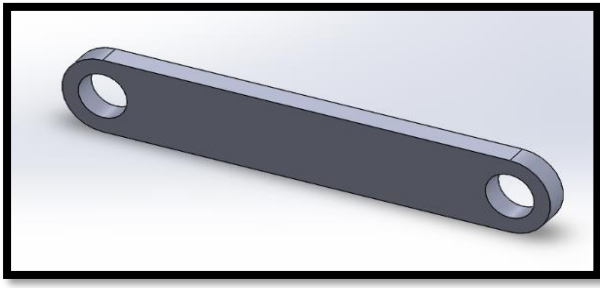

Fig. 6: Link C

D. Translation Element

We have dimensions L = 40mm and H = 30mm diameter, Inner diameter = 25mm diameter, Extended portion from center of translation element and they have hole of 6mm diameter. For translation element we use Aluminium in analysis.

As we know the force on spring from outside is around 42N. So the same force is applied on translation element and then on spring.

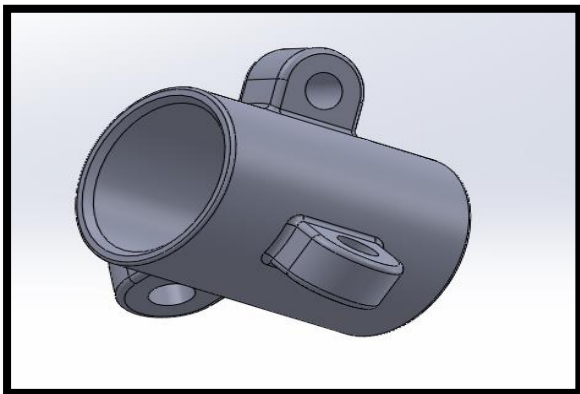

Fig. 7: Translation element

E. Central Frame

We have dimensions Total L = 300mm, H = 25mm diameter, and inner diameter = 17mm, Thickness of Extended Part = 8mm. Material use for this component is Aluminium in Analysis. There are total 6 extended parts on Center Frame 3 on 70mm from one

end and another 3 on 170mm from one end and the have hole of diameter 6mm.

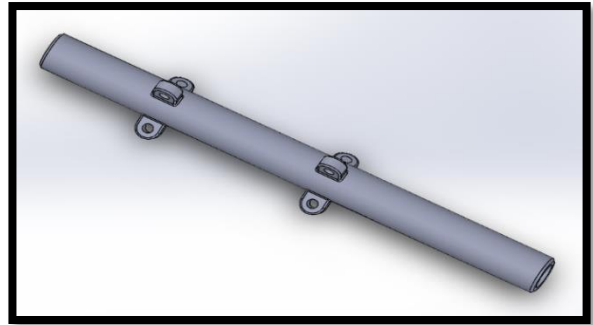

Fig. 8: Center Frame

F. Wheels

We have dimensions Total diameter = 62mm, Thickness = 12mm and at center hole = 6mm diameter.

Material for Wheels we use Aluminium in Analysis. As we know the total force on link and spring is same and this force or load is coming from Wheel therefore the force on wheel will be same. On each wheel 7N force is getting and on one link there are two wheels is there therefore total 14N on each link. On the surface of wheels there are many holes and at center the shaft of motor will be fix. As motor starts rotating the wheel also gets rotation and Robot starts crawl under the pipe.

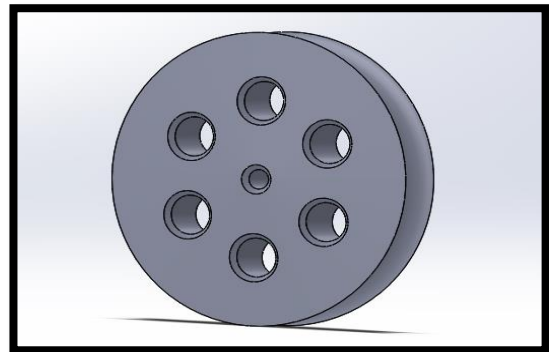

Fig. 9: Wheel

G. Rivets

There are total 24 rivets we have to use. Out of which 9 are link rivets, 6 are wheel rivets, 6 are center frame rivets and 3 are translation element rivets.

Dimensions we have L = 10mm, 19mm, 15mm, 18mm and H = 10mm diameter for all rivets.

We use material for Rivets is Aluminium in Analysis and we selected C-20 from PSG data book.

On rivets there are only shear stress acting. Therefore we have find shear value for that

$$\text{Shear stress} = \frac{\text{Shearing Force}}{\text{Area}}$$

$$\tau = \frac{14}{\frac{\pi}{4} \times 6^2}$$

$$\tau = 0.495 \text{ N/mm}^2.$$

We have Permissible stress = 160 N/mm².

And FOS = 3.

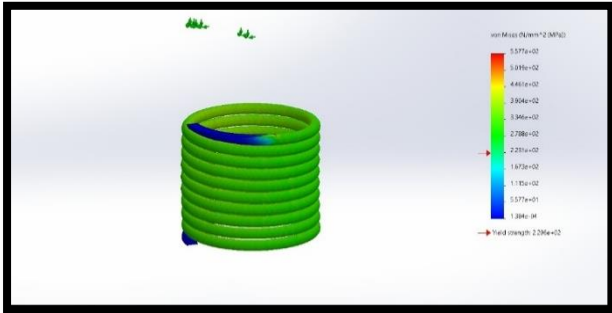
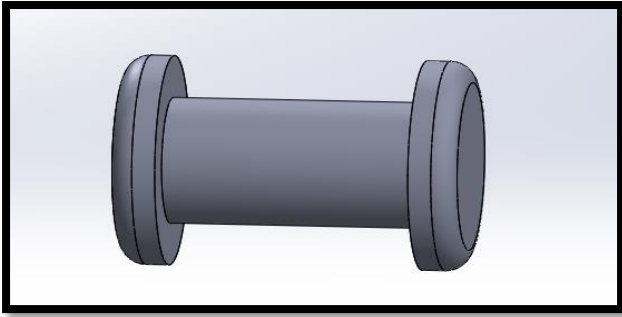

Fig. 10: Rivet

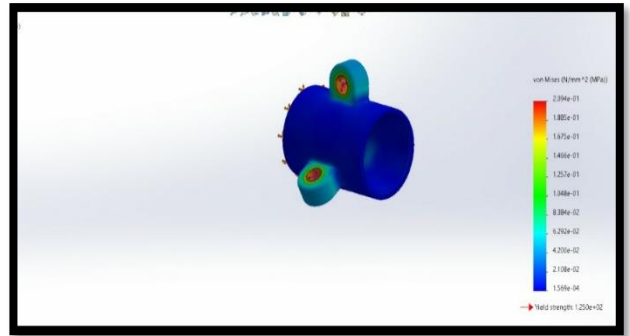
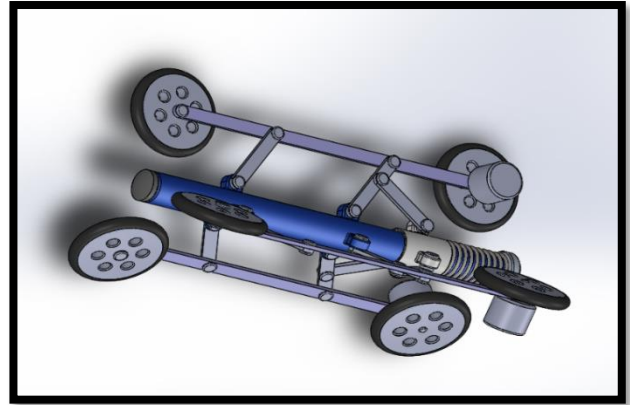

Fig. Analysis of Components

ASSEMBLY



ANALYSIS

For Analysis Purpose we use SolidWorks Simulation Software. We done the analysis on main parts only among them are Compression Spring, Link, Translation Element, Wheel and Rivet.

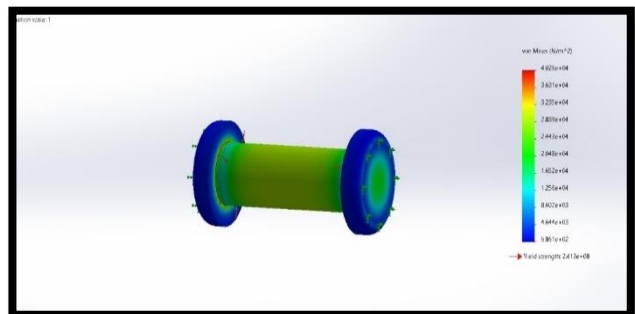
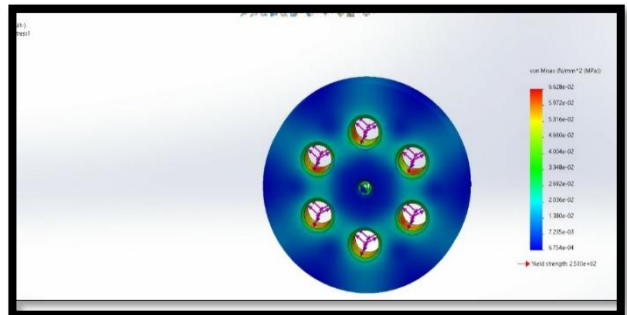
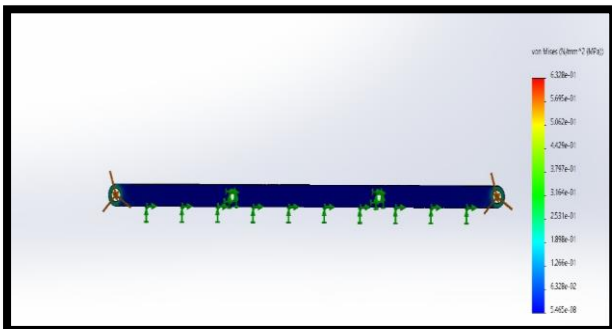
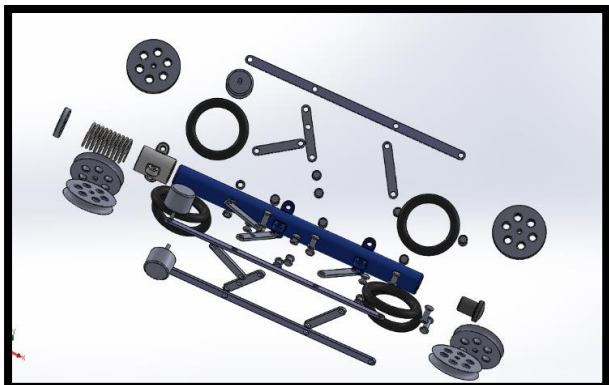

Fig. 12: Analysis of Components



4. COMPARISON OF RESULTS

S no.	Parameters	Calculation Results	Analysis Results	Difference
1	Max Permissible Stress	142.3MPa	149.8MPa	7.5MPa
2	Max Shear Stress	148.5KPa	160.3KPa	11.8KPa

5. CONCLUSION

The flexible autonomous inline pipe inspection robot is designed and fabricated. The design is prepared in SolidWorks to simulate the model. Our robot is able to inspect in practical situations. It has ability to travel in vertical as well as horizontal directions and turn in elbows. It is employed with dual locomotion system to achieve this goal. It helps to show the actual image inside the pipe. It able to easy to find defect, flaws, material decay, corrosion and crack. Robot have a good work accuracy and very fast in process than human being.

6. ACKNOWLEDGEMENT

We take this opportunity to express our gratitude to our project guide Prof. Umesh Solase for his excellent guidance, suggestions and constructive criticism. Working under his guidance greatly contributed in improving quality of our project work and our Engineering skills. Actually he is one of such genuine person for whom our words will not be enough to express.

We are extremely fortunate be involved in an exciting and challenging project work. This project has improved our thinking and understanding capability. We are also thankful to Prof. Satish Silaskar (Head of Department), Mechanical Engineering Department of New Horizon Institute Of Technology And Management, Thane for his constant support and encouragement.

7. REFERENCES

- [1] Jong-Hoon Kim, Gokarna Sharma, And S. Sitharama Iyengar "FAMPER: A Fully Autonomous Mobile Robot for Pipeline Exploration", Department of Computer Science, Louisiana, State University the USA 2010 pp 517-520.
- [2] Atul Gargade1, Dhanraj Tambuskar, Gajanan Thokal, "Modelling and Analysis of Pipe Inspection Robot", International Journal of Research In Engineering And Technology,2013, Pp 120-121.
- [3] Palwinder Kaur1, Ravinder Kaur, Gurpreet Singh, "Pipeline Inspection and Borewell Rescue Robot", International Journal of Research in Engineering and Technology,2014, Pp 726-728.
- [4] Xin Li, Wuyi Yu, Xiao Lin, and S. S. Iyengar, "On Optimizing Autonomous Pipeline Inspection," in IEEE Transactions on Robotics, Vol. 28, No. 1, February 2012.
- [5] Hanaa Said Salim Al-Hajry and G.R. Rameshkumar, "Designand Testing of Pipeline Inspection Robot," in International Journal.
- [6] J. Z. Z. X. Li, "Development of The Self-Adaptive Pipeline Cleaning Robot," In Advanced Materials Research, 2010, Pp. 97-101.
- [7] Hygenic Pigging Systems (U.D.) Retrieved from England Wales. Company No. 2974969 VAT No. GB 653 6975 93.

BIOGRAPHY



Deepak Sonawane

New Horizon Institute of Technology and Management, Thane, Maharashtra, India



Samadhan Bhosle

New Horizon Institute of Technology and Management, Thane, Maharashtra, India



Omkar Baile

New Horizon Institute of Technology and Management, Thane, Maharashtra, India



Omswarup Kotkar

New Horizon Institute of Technology and Management, Thane, Maharashtra, India