



INTERNATIONAL JOURNAL OF ADVANCE RESEARCH, IDEAS AND INNOVATIONS IN TECHNOLOGY

ISSN: 2454-132X

Impact factor: 4.295

(Volume 5, Issue 1)

Available online at: www.ijariit.com

Infant cradle monitoring system

Shasna M. A.

shasnakader97@gmail.com

Universal Engineering College,
Mathilakam, Kerala

Mohsina Mohamed Kabeer

mohsinamk1998@gmail.com

Universal Engineering College,
Mathilakam, Kerala

Navami Krishna U. A.

navamikrishnaammu12@gmail.com

Universal Engineering College,
Mathilakam, Kerala

Nedheela N. Nazar

nedheela1997@gmail.com

Universal Engineering College,
Mathilakam, Kerala

Nighila Ashok

nighilaabish@gmail.com

Universal Engineering College,
Mathilakam, Kerala

ABSTRACT

In today's world, we see that most of the families consist of mainly the parents and children. When a baby is born in a family there has to be someone to look after the baby. Some parents have to do a double task of keeping a check on the baby as well as do the household work. Keeping a nanny could be an option but not all can afford nannies and also it is always difficult for parents to rely on some strangers to look after their baby. So to help such parents we have decided to come up with a smart cradle which will help a mother or a father have a track of their child and do some household work simultaneously. The temperature and wetness sensor detects the temperature and wetness of the baby and if it increases a particular level, the message will be sent to the parents. The mic in the system detects, if the baby cries and a song will play through the speaker set up in the APR, also message is sent to the parents. Also, the feeding time of the baby is set using the keypad, and at that time message will be sent to the parents.

Keywords— APR, Blynk server, DC motor

1. INTRODUCTION

During the early stages, infants need proper rest and sleep for growth and development. Hence, it is the responsibility of the parents/guardian to provide the necessary care and attention to the infant. But with the modern lifestyle, parents are busy and have a lot of work with little time to provide for their little ones.

In today's world, we see that most of the families consist of mainly the parents and children. When a baby is born in a family there has to be someone to look after the baby. Some parents have to do a double task of keeping a check on the baby as well as do the household work. Keeping a nanny could be an option but not all can afford nannies and also it is always difficult for parents to rely on some strangers to look after their baby. So to help such parents we have decided to come up with a smart cradle which will help a mother or a father have a track of their child and do some household work simultaneously. As lives started

getting busier and parents to have a little time to provide for their little ones. The cradle systems started getting more modified. Many infant monitoring systems came into the market. Parenting infants is a difficult task in the initial stages. It becomes difficult for parents to understand the language of their infants but baby monitors help to try and understand their infants by providing them with vitals so the parents can understand the cause of uneasiness experienced by the baby. If a system could understand the uneasiness of the baby or why the baby might be crying it means that for both working and non-working parents could save their time and provide the necessary care and attention to the infant.

2. LITERATURE SURVEY

From the normal cradle to the automatic swing cradle, there are many types of the cradle. The use of baby cradle came in when the security of the baby was at risk. It would be more cosy for a baby to sleep in a cradle or in confinement which is specially made for them with extra bedding such as blankets or quilts. It was further modified in such a way that they are portable. Parenting infants is a difficult task in the initial stages. It becomes difficult for parents to understand the language of their infants but baby monitors help to try and understand their infants by providing them with vitals so the parents can understand the cause of uneasiness experienced by the baby.

Mainly, when the parents are not nearby, the swinging motion helps baby relax and take a short nap. This was why automatic swinging cradle was developed. It is one of the fantastic aids that was really helpful for parenting which is inexpensive and still in the market.

In [1] a cradle with a monitoring system is used. In Baby monitoring using surveillance the Smart baby monitor that lets you track sleep patterns and other useful data in a companion app. The optical zoom lens is a stand-out feature that adds flexibility. 1080p and 720p viewing is available. The available systems allow recording live videos and sounds of an infant.

Smartphone apps allow a user to monitor a camera-equipped device, such as another smartphone or a tablet. Alternatively, Wi-Fi or Bluetooth can link a camera to a dedicated app on a smartphone or tablet. This means a smart device doesn't need to be left in the baby's room. In a baby, monitors provide two-way communication which allows the parent to speak back to the baby (parent talk-back). This technology provides an interaction of the parent with the child when the parent is away from the child. This system includes surveillance systems also.

Mohit Kumar, Mrs Suryakala discussed a conventional approach to monitor the infant includes constant monitoring of infant using a web camera or keeping nurse for the baby or using audio monitoring.

But, this system provided peace of mind to parents when they were away from their infant as they can obtain the updates of the health of the baby. The fundamental part was that the communication was done by using a GSM interface in which Short Messaging Service (SMS).

Mrudula Borkar, Neha Kenkre, Harshada Patke[2] stated that warmth is an important parameter for the infant in an incubator. The system mainly focused on monitoring the desired temperature of infant incubator. The Arduino UNO is and the RF transmitter and receiver module were implemented and sends the data from a microcontroller to the computer for better monitoring purpose. N.A.A Hadi, M.H.C. Hasan, N.M.Z. Hashim, N.R.Mohamad, A.S. Rahimi, K.A.M. Annuar[5] stated that the current recommended method of providing infant temperature regulation in resource settings was Kangaroo Mother Care (KMC), the practice of placing newborns, directly onto the mother's chest.

Suruthi, S. Suma [3] implemented by monitoring the temperature and pulse rate using the appropriate sensors. The accelerometer was used as the motion sensor. The GSM Modem interfaced with the microcontroller sends an alert SMS to the parent's mobile number. Shijo Joseph Mathew, S. Mathankumar, S. Vaishnodevi [4] implemented that the single-chip microcontroller read the surrounding temperature, humidity, respiration along with the sensor. All the value was displayed on LCD. Single chip microcontroller was used to analyze all the three sensor data and any variation occurred, an alert was sent to parents automatically.

KMC has demonstrated benefits in terms of improved weight gain for preterm infants. In [6] used an Arduino Leonardo board in the system design along with a body temperature sensor, a sound detection sensor, a finger heartbeat detector, and a humidity sensor. Notification of alarm situations has been successfully provided via a vibrating smartwatch, SMS, and LEDs (Light Emitting Diode) using Arduino board and Android-based applications. Faruk AKTAS, Emre KAVUS, Yunus KAVUS [7] discussed about the temperature and pulse rate and also describes the design of a very low-cost remote baby monitoring system which measures heart rate and body temperature of an infant and sends the data to a remote end where the data will be displayed and parents or caretakers will be able to examine him/her. It [8] stated that the system was to monitor the parameters Like Light, respiration, the Audio/ voice of the baby that he/she was ok or crying. Door parameter to provide Intruder bell so that it provided an alarm/Led indication if any person entered in the place /Room of baby by breaking the sensor. In [9] automatic swinging cradle, when the parents are not nearby, the swinging motion helps baby relax and take a short nap. This was why automatic swinging cradle was developed. It is one of the fantastic aids that was really helpful for parenting

which is inexpensive and still in the market. This the most used existing system used nowadays. The cradle detects a crying baby using the mic along with the signal conditioning and the baby bassinet starts swinging with the help of a motor.

3. METHODOLOGY

Node MCU is the heart of the system. Node MCU is controlling the whole system. Initially, the cradle is swinging with a smooth melody with help of Speaker and motors. If there is a threshold change in Temperature, Humidity or Wet Sensor corresponding Action will be carried. If the Temperature exceeds the level that can be measured by the DHT11 and fan can be rotated. In case of cradle get wet that is sensed by the wet sensor and notification to change the cloth will be given to Parents by indication. Depending upon the babies growth feeding time can be set by mom on the system when the time comes indication will be available for the Mother. When the baby is crying it is observed and give notification for parents.

The Scenario of the cradle will be available on Blynk Server so if the parents can monitor any time through their Mobile. The different conditions are checked and the information is sent to the parent via the blynk server.

The microcontroller receives the three inputs- from the wireless sensor, microphone amplifier module and the temperature sensor. The input received through the microphone module is amplified whereas the inputs received from wetness and temperature sensor is given directly to the microcontroller. When the baby cries, the MCU gives output to the music generator circuit which produces soothing music and to the motor driver circuit which would gently swing the cradle. Simultaneously, a message is sent through the blynk server to the phone for intimating the parent or guardian.

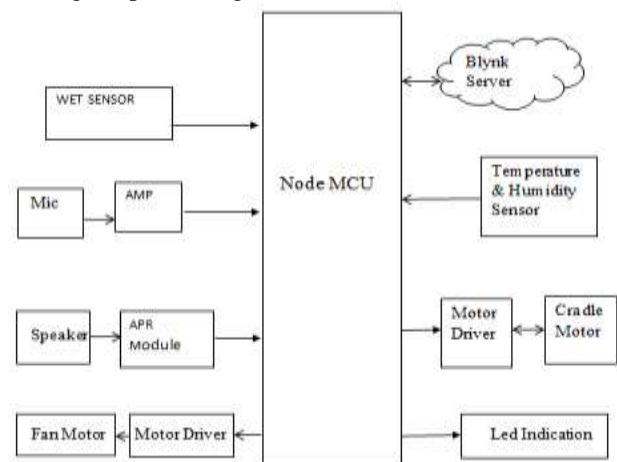

Fig. 1: Block diagram of the proposed system

4. COMPONENTS REQUIRED

4.1 Node MCU (ESP8266)

Node MCU controls the whole system. The MCU uses an Arduino platform. The MCU comes with an inbuilt Wi-Fi and uses embedded C. It is also adaptable with most sensors.

4.2 Wet Sensor

The wet sensor detects the wetness of the baby and alarms the parents to change the cloth of the baby.

4.3 Mic

When a baby cries in the cradle, the microphone detects it and converts the sound signal into an electrical signal. The electrical signal is then fed into an amplifier. A condenser microphone is used to detect the baby cry.

4.4 APR Module

The APR is a voice Recording Module. This is used so that a melody recorded is played on loop when the cradle swings. Thus it operates on the functioning of swinging.

4.5 Motor Driver (L293d) and DC Motor

It is connected through a driver circuit. Also, motors tend to be electrically noisy (spikes) and can pass power back into the control lines when its direction or speed is changed.

4.6 DHT11 (Temperature and Humidity Sensor)

The temperature sensor measures the temperature around the cradle and if the temperature is more than 39°C with respect to the room temperature, it alerts the parent. The temperature change around the cradle or in the room is one of the reasons the baby might be disturbed.

4.7 Speaker

When the microcontroller unit receives the information from the microphone, that frequency is checked and if the frequency is matched to baby crying frequency then automatically song is played.

4.8 Server

Blynk server is an IoT based server specially designed and targeted among students. This server is interactive and is used for sending, receiving, alarming the parents whenever needed.

5. CONCLUSION

Recent advances in sensor technologies and wireless communication technologies enable the creation of a new generation of healthcare monitoring systems with wearable electronics and photonics. Parents in the present world are busy in their professional life, so they do not get sufficient time to take care of their babies. It may be expensive for the household to afford a nanny. Today's woman has to manage home along with their office work simultaneously. After long working hours, they have to take care of the home along with the baby. They may not get enough time to swing the cradle manually and soothe the baby.

Moreover, in today's lifestyle, it is very difficult even for the housewives to sit nearby their infants and soothe them whenever they cry. This system is inexpensive and simple to use, which can improve the quality of parenting. It gives parents a feeling of assurance. The constant recording of multiple biological parameters of a baby and analysis of overall health helps a mother to understand the overall health condition of the baby and can take actions for improvement, if necessary. Cradle temperature and wetness is also measured. When the baby cries, he/she can be soothed by the music and the system intimates the situation to parents. As blynk server is used, communication can happen over longer distances. This is an efficient system for monitoring the baby's health condition from any distance. We

can also use the same system for monitoring a patient's health conditions and send information to a doctor.

6. REFERENCES

- [1] Mohit Kumar and Mrs Suryakala, "Temperature control and monitoring of incubators using IoT", *International Journal of Emerging Technology in Computer Science & Electronics (IJETCSE)* ISSN: 0976-1353 Volume 22 Issue 1 – MAY 2016.
- [2] Mrudula Borkar, Neha Kenkre and Harshada Patke, "An Innovative approach for Infant Monitoring System using Pulse Rate and Oxygen level", *International Journal of Computer Applications (0975 – 8887)* Volume 160 – No 5, February 2017.
- [3] Suruthi and S. Suma, "Microcontroller based baby incubator using sensors", *International Journal of Innovative Research in Science, Engineering and Technology (An ISO 3297: 2007 Certified Organization)*, Vol. 4, Issue 12, December 2015.
- [4] Shijo Joseph Mathew, S. Mathankumar and S. Vaishnodevi, "Portable neonatal Intensive care unit", *International Journal of Innovative Research in Science, Engineering and Technology*, (An ISO 3297: 2007 Certified Organization), Vol. 4, Issue 5, May 2015.
- [5] N.A.A Hadi, M.H.C. Hasan, N.M.Z. Hashim, N.R.Mohamad, A.S. Rahimi and K.A.M. Annuar, "Temperature Monitoring System for Infant Incubator Using Arduino", *International journal for advance research*, Volume 3, Issue VI, June 2015 ISSN 2320-6802.
- [6] Prof. Kranti Dive and Prof. Gitanjali Kulkarni, "Design of Embedded Device for Incubator for the Monitoring of Infants", *International Journal of Advanced Research in Computer Science and Software Engineering*, Volume 3, Issue 11, November 2013.
- [7] Faruk AKTAS, Emre KAVUS and Yunus KAVUS, "A Real-Time Infant Health Monitoring System for Hard of Hearing Parents by using Android-based Mobil Devices", *Faruk AKTAS et al. / IU-JEEE* Vol. 17(1), (2017), 3107-3112.
- [8] Sujal Rane, Kajal Sutar, Vaidehi Temghare, Prof. Rahul Patil and Prof. Sandip Chavan, "Baby Health Monitoring System using Wireless and Remote Access Technology", *International Journal of Recent Trends in Engineering & Research*
- [9] Steven Bang; Richard Lam; Natalia LoCicero; "Rock Me Baby: The Automatic Baby Rocker" Project for, San Jose State University, Department of Mechanical and Aerospace Engineering, May 17, 2011.
- [10] Anitha Ebenezer; Anupreethi. S; "Automatic Cradle Movement for Infant Care" *Undergraduate Academic Research Journal (UARJ)*, ISSN: 2278 – 1129, Vol.-1, Issue-1, 2012.