



INTERNATIONAL JOURNAL OF ADVANCE RESEARCH, IDEAS AND INNOVATIONS IN TECHNOLOGY

ISSN: 2454-132X

Impact factor: 4.295

(Volume 4, Issue 3)

Available online at: www.ijariit.com

Automated street lighting system using IoT

Prashanth Keni

keniprashanth@gmail.com

Rao Bahadur Y Mahabaleswarappa
Engineering College, Bellary,
Karnataka

Shaik Mohammed Wajid

wajidece.rymec@gmail.com

Rao Bahadur Y Mahabaleswarappa
Engineering College, Bellary,
Karnataka

Syed Zuber Ahmad

syedzuberahmad099@gmail.com

Rao Bahadur Y Mahabaleswarappa
Engineering College, Bellary,
Karnataka

Rahimunnisa

nazimaece.rymec@gmail.com

Rao Bahadur Y Mahabaleswarappa
Engineering College, Bellary,
Karnataka

Shruthi K

shruthirymec2014@gmail.com

Rao Bahadur Y Mahabaleswarappa
Engineering College, Bellary,
Karnataka

ABSTRACT

In this modern era where energy is a major concern worldwide, it is our prior responsibility & liability to save energy effectively. With the development of technology, where automation system plays a vital role in daily life experience and it is being preferred over the traditional manual system today. Here we propose an IOT based street light monitoring and controlling system to ensure, low power consumption, instant faulty light detection and light dimming as per external lighting conditions. Our proposed system consists of smart street lights that have external light sensing that automatically turns on at the desired intensity based on an amount of lighting needed.

Keywords: IoT, Arduino, ThingSpeak

1. INTRODUCTION

Nowadays, a human has become too busy and is unable to find time to switch the lights wherever not necessary. The present system is like the lights will be switched on in the evening before the sun sets and they are switched off the next day morning after there is sufficient light on the outside. But the actual timing for these lights to be switched on is when there is absolute darkness. With this, the power will be wasted up to some extent.

Streetlights are an integral part of any developing locality. They are present on all major roadways and in the suburbs too. Every day, streetlights are powered from sunset to sunrise at full strength, even when there is no one around. On a global scale, millions of dollars are spent each day on these street lights to provide the required electrical energy. The maintenance and replacement costs of conventional incandescent bulbs are immense. They consume a lot of electric power to function and their heat emissions are also quite high. All of this contributes to the greater demand for electricity production and consequently, more carbon dioxide emissions from powerhouses. So, along with unnecessary light pollution, this practice causes damage to our planet too.

2. FUNCTIONALITY DESIGN

2.1 Functional Description

The present system employs power delivery via a single-phase line to the streetlight. The proposed system involves five more components to regulate the power delivery. An Infrared Proximity Sensor at the base of the street light detects the presence in a small area around the street light. The data from the sensor is sent to the Arduino which forms brain of the circuit. The Arduino then commands to switch between dim and bright modes depending upon the Requirement and thus controls the brightness of the street light. A battery eliminator, also Powered by the single-phase line, is used to supply 5V inputs to the sensors and Arduino.

The design basically includes three working modes: -

1. **OFF mode:** When there is enough natural light in the surrounding i.e. during the daytime, the entire system is switched off and the batteries are charging.
2. **Active mode:** When the natural light drops below a certain level the system automatically turns on and the motion sensors are powered.
3. **ON mode:** On the presence of pedestrians, the sensors turn on which in turn switches on the LED lights. These lights turn off after a period.

To practically implement the above features, the arrangement of various devices in our system is as shown in the following block.

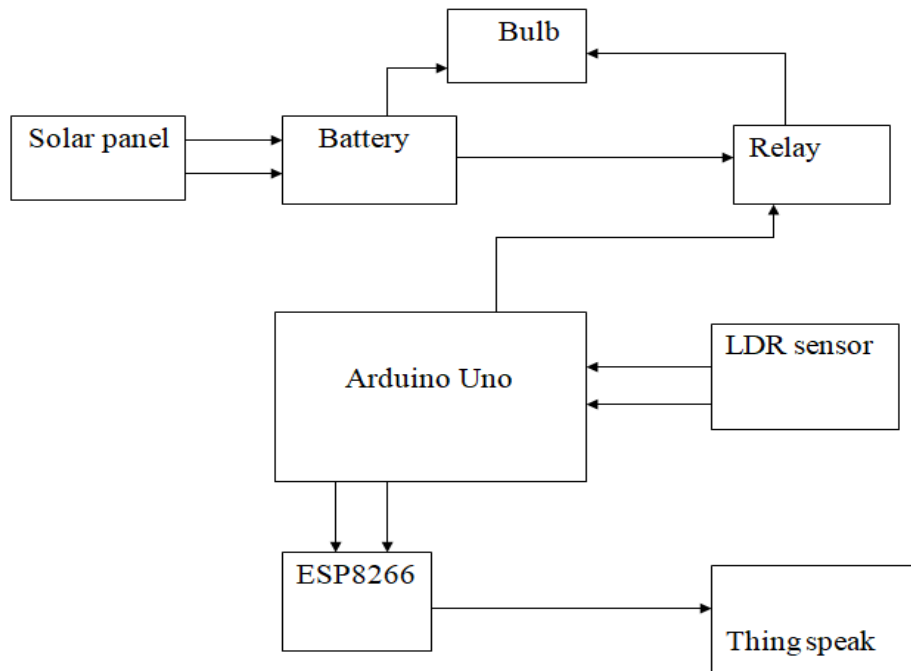

Fig. 1: Block diagram of Automated Streetlight

1. This block diagram describes the working of project ‘Solar smart Streetlight System with IoT’.
2. The solar panel of 10Watt is used here with will convert the incoming sunlight into electrical energy and used to charge the battery using switching circuit which converts the varying voltage into stable voltage.
3. Now this charged battery is used as a supply source to rest of the system.
4. Through battery, we will provide supply to Arduino which is controlling the functioning of LDR.
5. LDR senses the intensity of sunlight which is falling on it and passes this information to the Arduino Uno as shown in block diagram. Then the Arduino Uno processes this value and compares this value with the predefined threshold.
6. If the sensed value by LDR is less then predefined threshold then the Arduino Uno switches the relay to a closed switch and the LED will glow, when the sensed value is greater than the threshold then the Arduino switches the relay to off state and the LED will turn off automatically.
7. The state of LED, the intensity of sensed sunlight and threshold value information is transferred to thingspeak with the help of esp8266.
8. Finally, we can observe the graphs by logging in to thing speak.

3. FEASIBILITY STUDY

3.1 Technical:

Arduino is a single-board microcontroller, intended to make the application of interactive objects or environments more accessible. The hardware consists of an open-source hardware board designed around an 8-bit Atmel AVR microcontroller or a 32-bit Atmel ARM. Current models feature a USB interface, 6 analog input pins, as well as 14 digital I/O pins which allows the user to attach various extension boards.it operates with a voltage of 4.5-5V.

3.2 Economical:

The components like Arduino Uno, ESP8266, LDR, led costs low. From an economic point of view, the cost of purchasing hardware is low. Ultimately, the implementation of this project will reduce the expenditure on power supply board.

3.3 Operational:

The module provides a very user-friendly interface and does not need extra training for usage.

4. APPLICATIONS

- We can use it outside the house, corridors or industry area, which helps to save power.
- In sea off-shore side we can use it as a dangerous sign.
- Street lights use photoresistors to detect whether it is day or night and turn the light on or off accordingly.
- It can be used in some clocks, alarms, and other electronic devices that are dependent on sunlight

5 ADVANTAGES AND DISADVANTAGES

5.1 Advantages:

- Solar street light is independent of the grid as a result of this operating cost is much low.
- Maintenance cost is much low compared to conventional street light.

- It is environmentally friendly, no harmful emissions.
- Longer life compared to conventional street lights.
- Power consumption is much lower.
- LDRs are sensitive, inexpensive and readily available devices. They have good power and voltage handling capabilities, similar to those of a conventional resistor.
- They are small enough to fit into virtually any electronic device and used all around the world as a basic component in many electrical systems.
- Photoresistors convert light into electricity and are not dependent on any other force.
- Photoresistors are simply designed and are made from materials that are widely available, allowing hundreds of thousands of units to be produced each year.

5.3 Disadvantages

- The initial investment is very high.
- Rechargeable batteries have to be replaced from time to time.
- Non-availability of sunlight during rainy and winter seasons is a problem.
- Dust accumulation on the surface of panel creates a problem.
- IOT is dependent on the internet.

6. RESULTS AND DISCUSSION

6.1 RESULT

The paper aims were to reduce the side effects of the current lighting system and find a solution to save power. In this project, the first thing to do is to prepare the inputs and outputs of the system to control the lights. The project shown in the figure has been implemented and works as expected and will prove to be very useful. The below graphs (display) are displayed in ThingSpeak.

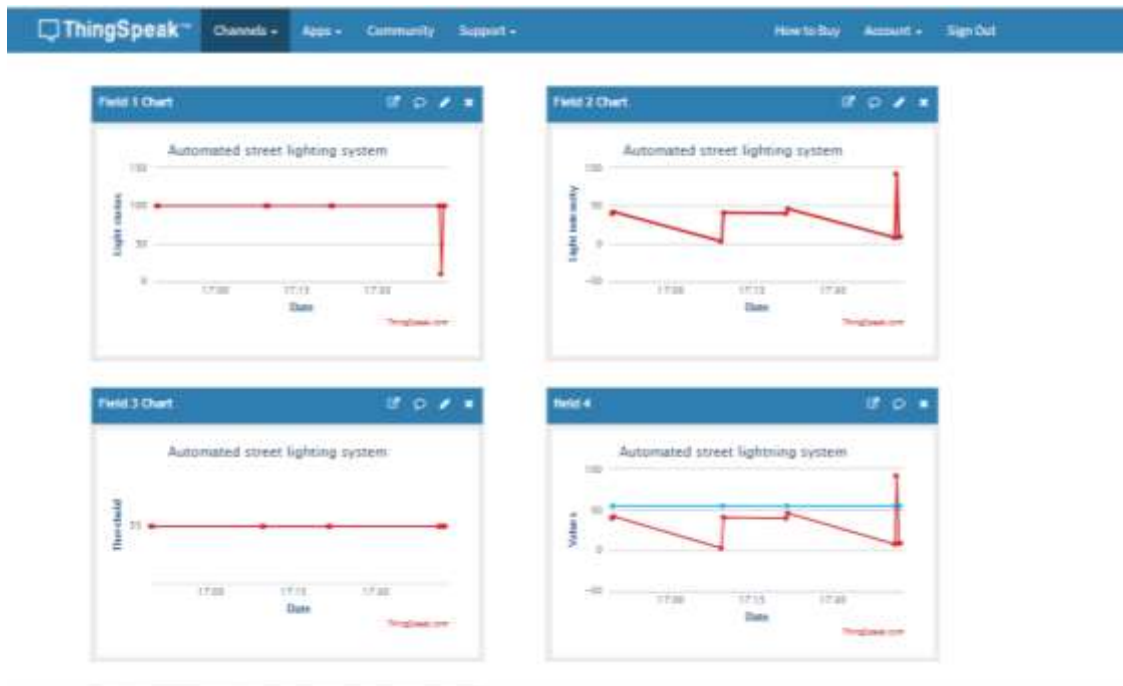

Fig 2: IOT display on thingspeak

In the above figure the first graph shows status of the light and the light intensity figure shows the intensity of light which is sensed by the LDR sensor if the sensed value is less than 50 then the LED should turn on. The third figure shows the value which we kept as a threshold that is 50. And the last fourth graph shows the intensity of sensed value of LDR with the threshold. In the first field, it shows the status of the light. In the graph, if the value of light status is 100 it means the light is ON. If the status of light value falls to zero that means the light is in OFF state.

The second field shows the light intensity value sensed by the LDR sensor. The third field shows the threshold value. If the sensed value is less than the predefined threshold then Arduino Uno will switch on the relay, and if the sensed value is above the threshold then the relay will be switched to off state. Because of open circuit light goes off. The fourth field in the graph gives the comparison between the sensed value and threshold value.

6.2 Challenges

- Switching of LED Strips when the vehicle is present based on the voltage supply.
- Interfacing of Arduino to the web browser.
- Displaying serial monitor data of Arduino onto the web browser.
- Fixing the range of LDR.

6.3 Limitations

- Variation Input voltage.
- The sensors used are not suitable for real-life setup.
- Power LED should be of greater voltage for actual setup.

7. FUTURE SCOPE

Using this smart project, we can also estimate the speed of the vehicle, recognizing the number plate, recognizing the accidents took place on roads etc. This Smart Streetlight project not only helps in rural areas but also beneficial in urban areas too. As we are moving towards more advancement we require more power to the use of renewable resources is useful and advantageous. With this project, we can even add smart parking of a vehicle and it is even useful for driverless cars. This project has a bright future not only to save power but also reduced the calamities and even reduce the crime rate.

8. CONCLUSION

The use of power electronics is increasing exponentially across various sectors of human life. The components used in the project, like Arduino and sensors are slowly becoming an indispensable part of our daily routines. So, it is only fitting that we use them to improve efficiency in every walk of life. Keeping in mind the urgent need for energy conservation, Solar Smart Street Light System with IoT is an excellent and effective solution. It combines safe lighting protocols with consumption of a minimal amount of power. The energy savings, as discussed before are phenomenal. The future scope of this project expands into speed detection and customizable area of illumination. An additional component which would lead to better functioning of the concept would be the use of LED bulbs. Despite their high initial costs, they are a viable option as they drastically reduce the power consumption. They will aid in further saving of energy and reduction in operational cost.

9. REFERENCES

- [1] 2017 IEEE Region 10 humanitarian Technology conference (R10-HTC)
- [2] <https://en.wikipedia.org/wiki/ESP8266>
- [3] Thing Speak.com
- [4] <https://store.arduino.cc/usa/arduino-uno-rev3>
- [5] http://www.fecegypt.com/uploads/dataSheet/1480848003_2_channel_5v_10a_relay_module.pdf
- [6] Cho, S. K., and Dhingra, V. (2008). "Street Lighting Control Based on Lon Works Power Line Communication," IEEE International Symposium on Power Line Communications and Its Applications, Jeju City, 2-4 April 2008, pp. 396- 398.
- [7] International Telecommunication Union. (2005). Internet reports 2005: The internet of things. Geneva: ITU.
- [8] Hachem, S., Teixeira, T., & Issarny, V. (2011). Ontologies for the internet of things (pp. 1–6). New York: ACM.
- [9] Wan, J., Yan, H., Suo, H., & Li, F. (2011). "Advances in cyber-physical systems research", KSII Transactions on Internet and Information Systems, 5(11), 1891–1908.
- [10] Tsai, C., Lai, C., & Vasilakos, V. (2014). "Future internet of things: Open issues and challenges". ACM/Springer Wireless Networks.
- [11] Atzori, L., Iera, A., and Morabito, G. (2010). "The internet of things: A survey," Computer Networks, 54 (15), 2787–2805.doi: <https://doi.org/10.1016/j.comnet.2010.05.010>