



# INTERNATIONAL JOURNAL OF ADVANCE RESEARCH, IDEAS AND INNOVATIONS IN TECHNOLOGY

ISSN: 2454-132X  
Impact factor: 4.295  
(Volume 4, Issue 3)

Available online at: [www.ijariit.com](http://www.ijariit.com)

## Air pollution modelling

Kulshresth Singh

[kispf02@gmail.com](mailto:kispf02@gmail.com)

Indian Institute of Engineering Science and Technology,  
Shibpur, West Bengal

### ABSTRACT

*Industrial chimney releases pollutant to the environment which causes air pollution. As an air pollutant is transported from a source to a potential receptor the pollutant disperses into the surrounding air so that it arrives at a much lower concentration than it was on leaving the source. Air pollution modeling helps to determine the mathematical relationship between the effects of source emission of the pollutant on ground level concentration. Many dispersion models have been developed and used to estimate the downwind ambient concentration of air pollutants from sources such as industrial plants, vehicular traffic or accidental chemical release. Air Pollution emission plume i.e., the flow of pollutant in the form of smoke released into the air. Throughout many dispersion models, Gaussian Dispersion Models perhaps the oldest (circa 1936) and perhaps the most commonly used model type. The primary algorithm used in Gaussian modeling is the Generalized Dispersion Equation for a continuous point source plume. This paper reviews the air pollution modeling which relates the effects of source emission on ground level concentration by mathematical equations and terminology.*

**Keywords:** Air Pollutant dispersion model, Gaussian dispersion model, Point source, and Plume dispersion.

### 1. INTRODUCTION

In urban areas, the dispersion of air pollution is very much high and it is becoming of great concern in the scientific community. The increasing levels of air pollution in many countries make attention towards the monitoring systems for air pollution. In such scenario, many air quality models to predict, study and evaluate the pollution dispersion have been studied and implemented. Air quality models are able to predict the pollutant gases or aerosol trajectories in the atmosphere. Air pollution modeling is a numerical tool used to describe the relationship between emissions, meteorology, atmospheric concentrations, depositions and other factors. Including Gaussian dispersion model, other dispersion model types are Box model, Lagrangian model, Eulerian model and Dense gas model. Basically, the question arises here, why we use mathematical modeling to idealize the concept of air pollutant dispersion? "A mathematical model helps to quantify the complex theoretical problems and assessing quantitative conjectures or in other words, it is an experimental tool by which analyzing of testing theories is done by using mathematical methods and formulations. The concept of mathematical modeling applied to air pollution:

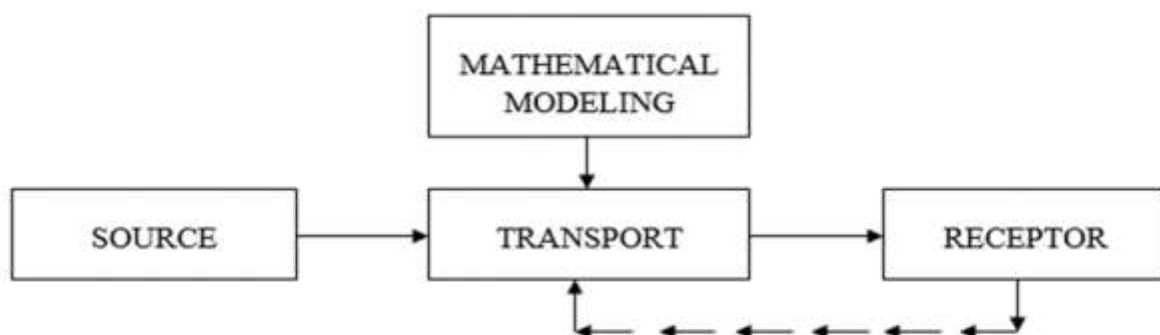

Source: Point, line, area

Transport: decides the fate for air pollution

Receptor: humans

Mathematical modeling applied to transport of air pollutant dispersion.

## 2. AIR POLLUTANT EMISSION

Basically, when we go for industrial air pollutant emission source, they are:

- i. **Point Source-** Single, identifiable source of air pollutant emissions and also it can be characterized as either elevated or at ground-level. Example: the emissions from the industrial chimney.
- ii. **Line Source-** the One-dimensional source of air pollutant emissions. Example: the emissions from vehicular traffic on the roadway.
- iii. **Area Source-** the Two-dimensional source of air pollutant emissions. Example: the emissions from a forest fire.
- iv. **Volume Source-** Three-dimensional source of air pollutant emissions. Example: the fugitive gaseous emissions from piping flanges, valves and other equipment's at various heights within industrial facilities.

## 3. AIR POLLUTION DISPERSION MODELS

Modeling of air pollution dispersion is classified into five types:

1. Box Model
2. Gaussian Model
3. Lagrangian Model
4. Eulerian Model
5. Dense gas model

### 3.1 Box Model

Box model as shown in fig. 1 is the schematic diagram of box model of simple urban air quality including source emissions, advective inflow and outflow to and from the sides, entrainment and detrainment of pollutants aloft due to increasing and decreasing of rising mixed height or vertical height (h), chemical transformations and wind direction. The length, breadth and height of box model represents downwind dimension (l), crosswind dimension (m) and vertical dimension (h). Since uniform mixing is assumed to occur within the box whose horizontal boundaries enclose the urban area of interest, the model can predict only the volume-averaged concentration as a function of time. In box model, instead of individual source of emission, we considered all sources in estimating source emissions within the box. For the simplest box model without chemical transformations, one can derive a simple differential equation for the average concentration  $\bar{c}$  within the box from the consideration of mass conservation within the box. The rate of change of mass within the box must be equal to the sum of the rates at which the pollutant mass is added by all the emission sources in the box, the change due to horizontal advection, and the change due to entrainment from the top resulting from the growth in mixed height. This can be expressed in mathematically as-

$$lh \frac{d\bar{c}}{dt} = lQ_a + \bar{u}h(\bar{c}_b - \bar{c}) + l \frac{dh}{dt} (\bar{c}_a - \bar{c}) \quad \text{-Equation 3.1.1}$$

Where,

$\bar{c}_a$  is the average concentration aloft over the city,

$\bar{c}_b$  is the average background concentration upwind of the city.

Equation 3.1.1 can be rewritten in the form,

$$\frac{d\bar{c}}{dt} + \left( \frac{\bar{u}}{l} + \frac{1}{l} \frac{dh}{dt} \right) \bar{c} = \frac{Q_a}{h} + \frac{\bar{u}c_b}{l} + \frac{1}{h} \frac{dh}{dt} \bar{c}_a \quad \text{-Equation 3.1.2}$$

Which can be solved easily for the specified values of  $Q_a, \bar{c}_a, c_b, \bar{u}, h$  and  $dh/dt$ .

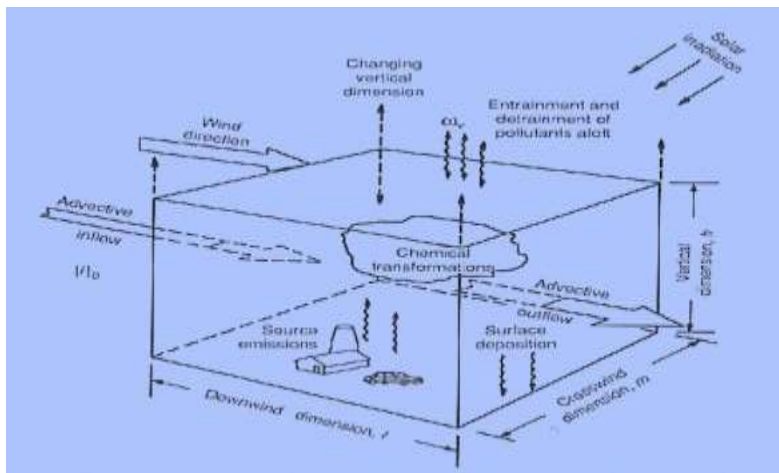

Fig. 1 Schematic diagram of the box model. (source: Air quality modeling for teachers,[online], 2018)

According to the above simple box model, first proposed by Lettau (1970), the concentration decreases exponentially with increasing time and approaches its equilibrium value given by equation 3.1.3 after a time two or three times the flushing time. Because of its simplicity, this type of box model is often used as a screening model in regulatory applications.

$$\bar{c}_e = \frac{l Q_a}{h \bar{u}} \quad \text{-Equation 3.1.3}$$

from equation 3.1.2, ( $\bar{c}_e = 0, \bar{c}_b = 0$ ). Furthermore, if conditions become steady state ( $d\bar{c}/dt = 0, dh/dt = 0$ ), then the equilibrium concentration is given simply by equation 3.1.3.

### 3.2 Gaussian Model

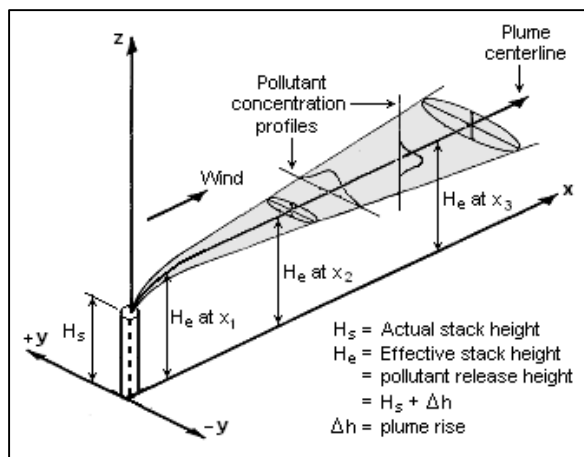

Fig. 2 Buoyant Gaussian air pollutant dispersion plume model (source: urban air pollution modeling, [online], 2018)

Gaussian plume model was developed for the purpose of understanding of the diffusion properties of plumes emitted from industrial stacks. This model is applied to calculate the maximum ground level impact of plumes and the distance of maximum impact from the source. Experimentally it is described by plotting standard deviation of its concentration distribution, in both the vertical and horizontal direction, as a function of the atmospheric stability and downwind distance from the source as shown in fig. 3.

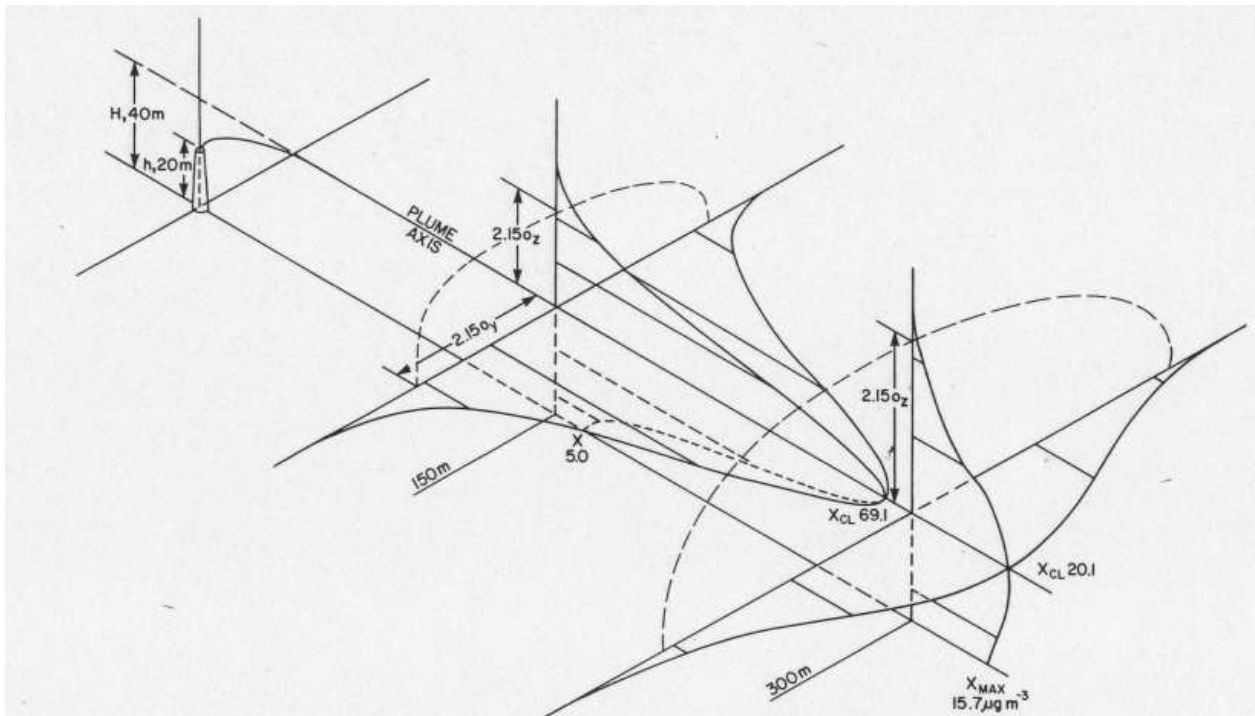

Fig. 3 Experimentally description of Gaussian plume model (Boubel et al., 1994)

The plotting is presented in the figure below:

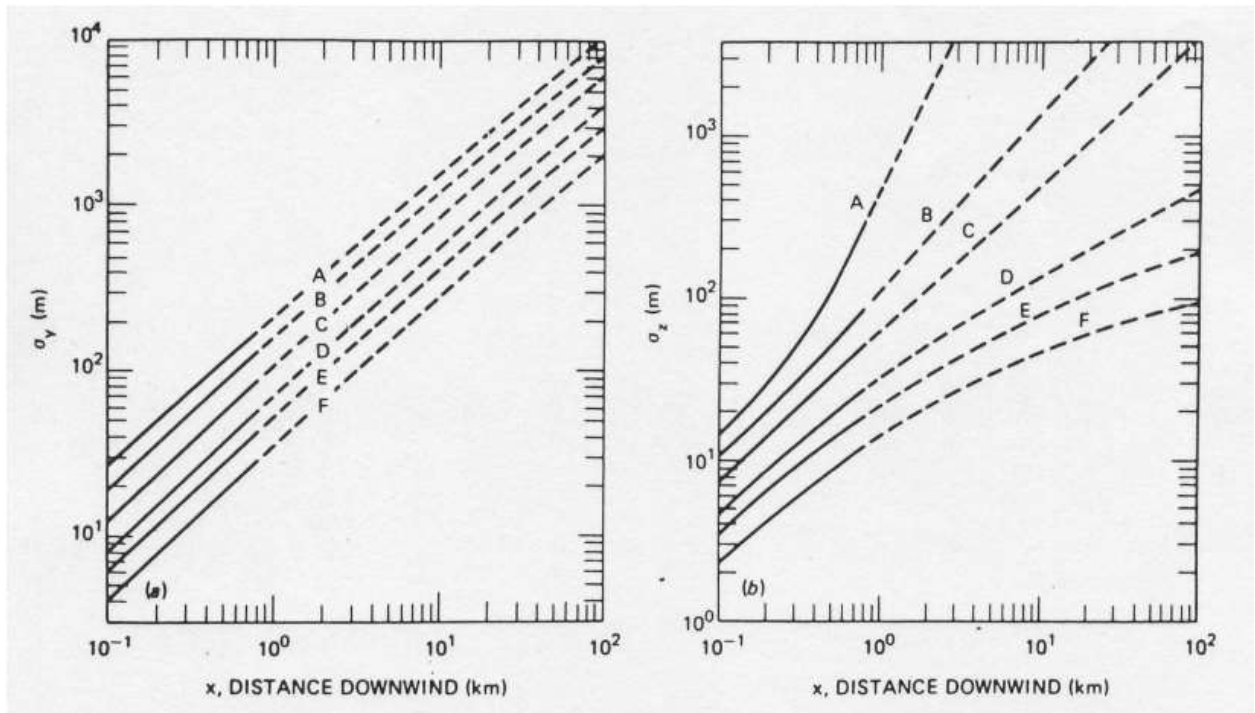

Fig. 4 Pasquill-Gifford  $\sigma_y$  (left) and  $\sigma_z$  (right). (source: from Gifford)

Pasquill Atmospheric stability class is the commonly used method developed by Pasquill in 1961 of categorizing the amount of atmospheric turbulence and is given below:

Table 1: Pasquill Atmospheric Stability Class

Stability Class	Definition	Stability Class	Definition
A	Very unstable	D	Neutral
B	Unstable	E	Slightly stable
C	Slightly unstable	F	Stable

Table 2: Meteorological conditions that define the Pasquill Stability Class

Surface	Wind speed		Daytime incoming solar radiation			Night time cloud cover	
	m/s	mi/h	Strong	Moderate	Slight	>50%	<50%
<2	<5		A	A-B	B	E	F
2-3	5-7		A-B	B	C	E	F
3-5	7-11		B	B-C	C	D	E
5-6	11-13		C	C-D	D	D	D
>6	>13		C	D	D	D	D

In the model, determining the pollutant concentrations at ground level beneath an elevated plume involves two main steps:

- The height to which the plume rises at a given downwind distance from the plume source is calculated. The calculated plume rise is added to the height of the plume's source point to obtain the so-called "effective stack height".
- The ground level pollutant concentration beneath the plume at the given downwind distance is predicted using the Gaussian dispersion equation.

By performing a mass balance on a small control volume, a simplified diffusion equation, which describes a continuous cloud of material dispersing in a turbulent flow, can be written as:

$$\frac{dC}{dt} + U \frac{dC}{dx} = \frac{d}{dy} \left( K_y \frac{dC}{dy} \right) + \frac{d}{dz} \left( K_z \frac{dC}{dz} \right) + S \quad \text{Equation 3.2.1}$$

Where,

x is the along-wind coordinate direction,

y is the cross-wind coordinate direction,

z is the vertical coordinate measured from the ground,

C is the ground level concentration,

$K_y, K_z$  is the eddy diffusivities in the direction of the y and z-axes ( $m^2/s$ ),

U is the average wind velocity along the x-axes,

S is the source term.

Analytical solutions to this equation for the case of dispersion of passive pollutants in a turbulent flow were first obtained in the 1920's by Roberts (1923) and Richardson (1926).

The Gaussian plume model is obtained from the analytical solution to equation 3.2.1 for a continuous point source released at the origin in a uniform turbulent flow:

$$C(x, y, z) = \frac{Q}{4\pi x \sqrt{K_y K_z}} \exp\left(\frac{-y^2}{4K_y x/U}\right) \exp\left(\frac{-z^2}{4K_z x/U}\right) \quad \text{Equation 3.2.2}$$

In most cases of flowing of air pollutant,  $K_y$  and  $K_z$  are unknown and in the atmospheric boundary layer  $K_z$  is not constant but increases with height above the ground. Despite these limitations, the general Gaussian shape of equation 3.2.2 is often. If we define the following Gaussian parameters:

$$\sigma_y = \sqrt{2K_y \frac{x}{U}} \text{ and } \sigma_z = \sqrt{2K_z \frac{x}{U}}$$

Then the final form of the Gaussian dispersion equation which is developed by Sir Oliver Graham Sutton (1932) and can be written as-

$$C(x, y, z) = \frac{Q}{2\pi\sigma_y\sigma_z U} \exp\left(-\frac{y^2}{2\sigma_y^2}\right) \times \left\{ \exp\left(-\frac{(z-H)^2}{2\sigma_z^2}\right) + \exp\left(-\frac{(z+H)^2}{2\sigma_z^2}\right) \right\} \quad \text{Equation 3.2.3}$$

Where,

C is the ground level concentration,

Q is the emission rate of the pollutant from the source,

u is the wind speed which defines the direction x,

y is the horizontal distance perpendicular to the wind direction,

z is the vertical direction,

H is the effective height of the plume i.e.,  $H = h + \Delta h$

$\sigma_y$  and  $\sigma_z$  are the parameters of the normal distributions in y and z directions.

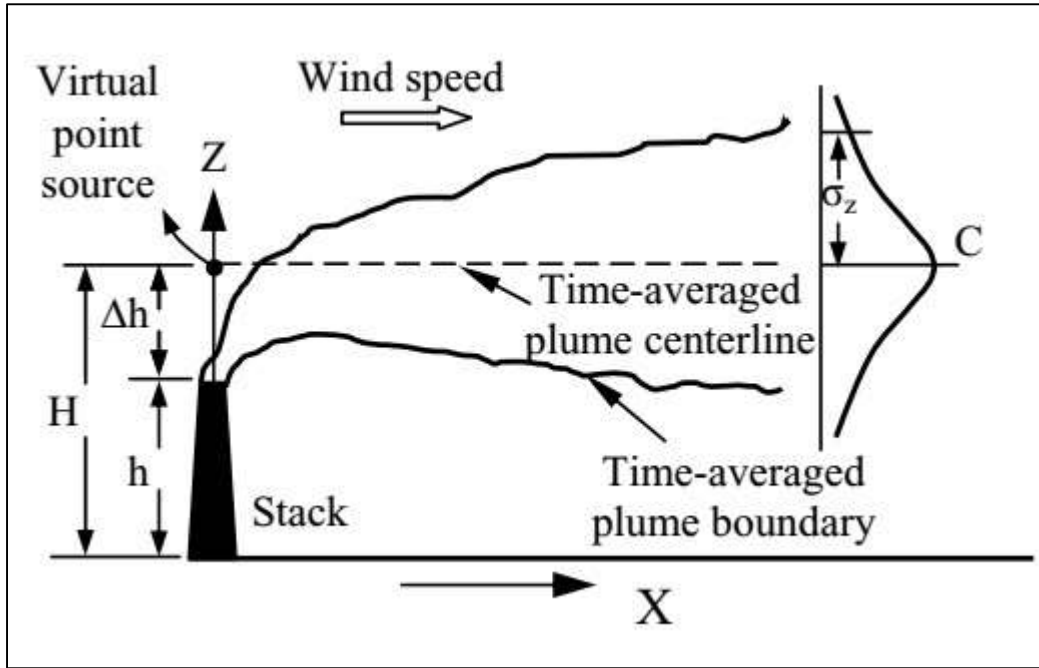

**Fig. 5 A schematic diagram of Plume dispersion**

Equation 3.2.3 is well known Gaussian plume equation for a continuous point source which is assumed by the ground to be a perfect reflector. Any receptors at the ground surface, the ground level concentration at  $z = 0$  is obtained as:

$$C(x, y, z = 0) = \frac{Q}{\pi\sigma_y\sigma_z u} \exp\left(-\frac{y^2}{2\sigma_y^2} - \frac{H^2}{2\sigma_z^2}\right) \quad \text{Equation 3.2.4}$$

In analyzing the Gaussian plume model, the following assumptions are usually made:

- i. Continuous emission and negligible diffusion in the direction of travel.
- ii. The material diffused is a stable gas or aerosol, with a negligible deposition rate.
- iii. Mass is conserved through reflection at surfaces.
- iv. Background pollution is negligible.
- v. Steady-state conditions.
- vi. Constant wind speed and direction with time and elevation.
- vii. Negligible wind shear effect on horizontal diffusion.
- viii. The dispersion parameters are assumed to be functions of x (and hence U alone).
- ix. The terrain is relatively flat, open country.

Gaussian plume models are applicable for downwind distance,  $x > 100$  m because near the source concentration approaches infinity (Briggs, 1973). From the Gaussian dispersion equation,  $\sigma$  is the dispersion coefficient which defines the plume dispersion. By plotting the standard deviation of its concentration distribution, the normal distribution assumed to be 67% of the pollutant within  $\pm\sigma$  of the centerline of the plume and it may be approximately four to six  $\sigma$  wide. The value of  $\sigma$  is determined by the magnitude of the turbulence in the atmosphere. Unstable atmosphere defines larger eddies and larger values of  $\sigma$  and stable atmosphere defines smaller eddies and smaller values of  $\sigma$ .

With  $y = 0$ , the equation 3.2.4 will be simplified to the following downwind ground level concentration form:

$$C(x, y = 0, z = 0) = \frac{Q}{\pi\sigma_y\sigma_z u} \exp\left(-\frac{H^2}{2\sigma_z^2}\right) \quad \text{Equation 3.2.5}$$

Using this equation, the effect of variations in the key parameters (atmospheric stability, wind speed, ambient temperature, stack height, gas exit velocity, and gas exit temperature) on the ground concentrations are calculated and shown as a composite plot in fig. 6.

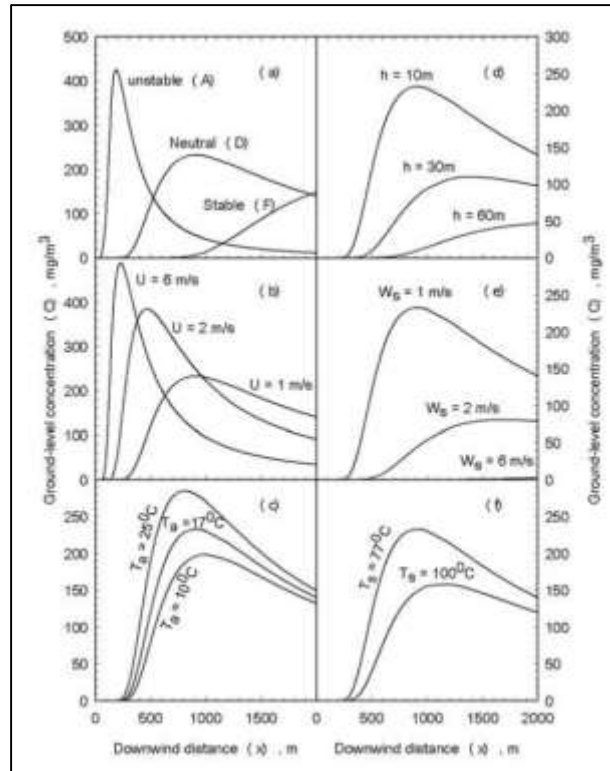

Fig. 6 Effect of key parameters on the downwind ground-level concentrations

From this figure, it is clearly seen that the plume center-line concentration drops off while the ground-level concentration goes higher and it continues till the asymptote to the same value is not achieved. It is the indication of the uniform distribution of the pollutant concentration with height (z).

### 3.3 Lagrangian Model

The basic phenomena on which lagrangian model based is pollutant air-parcel move along trajectories determined by the wind field, the buoyancy, and the turbulence effects. The lagrangian model determines to calculate these trajectories by the ordinary differential equation and partial differential equation. Lagrangian models without grid it can be solved easily unlike Eulerian models thus it helps to eliminate spatial discretization errors.

The trajectory equation for a single particle is written as an ordinary differential equation

$$\frac{d\vec{r}}{dt} = \vec{v} + \vec{v}_t \tag{Equation 3.3.1}$$

Where,

$\vec{r}$  is the position of the particle,

$\vec{v}$  is the grid-scale particle speed including advection, settling and buoyancy,

$\vec{v}_t$  is the turbulent wind fluctuation vector.

The Lagrangian parcel-trajectory model follows standard assumptions employed by classical puff dispersion models (e.g. Draxler and Taylor 1982). For a pollution puff initially released at a point and diffusing in an environment of spatially constant winds and diffusivities, limited vertically by the surface ( $z = 0$ ) and planetary boundary layer (PBL) top, the concentration around the puffed center are analytically calculated using:

$$C(x, y, z) = \frac{Q}{(2\pi)^{3/2}\sigma_y\sigma_z} \exp\left(\frac{-(x-x_c)^2 - (y-y_c)^2}{2\sigma_y}\right) \times \left[ \exp\left(\frac{-(z-z_c)^2}{2\sigma_z}\right) + \exp\left(\frac{-(z+z_c)^2}{2\sigma_z}\right) \right] \tag{Equation 3.3.2}$$

Where,

The center of the puff (located at  $x_c$  and  $y_c$ ) is calculated following a trajectory,

$z_c$  is the puff emission height (500m),

$\sigma_y$  and  $\sigma_z$  are the horizontal and vertical dispersion of pollutant mass around the puff center.

The effect of buoyancy can be estimated with the plume rise parameterization.

Puff models calculate the effect of turbulence in two different ways:

- i. The stochastic random-walk approach in the trajectories of the puffs. From equation 3.3.1 i.e.,

$$\frac{d\vec{r}}{dt} = \vec{v} + \vec{v}_t$$

- ii. Through the deviation of a normal distribution inside each puff. From equation 3.3.2 i.e.,

$$C(x, y, z) = \frac{Q}{(2\pi)^{3/2}\sigma_y\sigma_z} \exp\left(\frac{-(x-x_c)^2 - (y-y_c)^2}{2\sigma_y}\right) \times \left[ \exp\left(\frac{-(z-z_c)^2}{2\sigma_z}\right) + \exp\left(\frac{-(z+z_c)^2}{2\sigma_z}\right) \right]$$

### 3.4 Eulerian Model

Eulerian model is similar to Lagrangian model but only the difference is Eulerian model uses the fixed 3D Cartesian grid as a frame of reference rather than a moving frame of reference. The three-dimensional advection-diffusion equation forward in time (t) on a Cartesian grid:

$$\frac{dC}{dt} = \nabla(K\nabla C) - \nabla(\vec{v}C)$$

Where,

C is the pollutant concentration,

K is the turbulent diffusion coefficient,

$\vec{v}$  is the velocity vector

For this study, eddy diffusion coefficients are horizontally uniform and constant in time, but vary with height (z) and are set to zero at the PBL top, and at the surface (z = 0). Eulerian models monitor atmospheric properties, including temperature, pressure, and chemical concentration of tracers, over time.

### 3.5 Dense Gas Model

The Dense Gas Dispersion Model (DEGADIS) is a mathematical dispersion model that can be used to model the transport of toxic chemical releases into the atmosphere. Its range of applicability includes continuous, instantaneous, finite duration, and time-variant releases; negatively-buoyant and neutrally-buoyant releases; ground-level, low-momentum area releases; ground-level or elevated upwardly-directed stack releases of gases or aerosols. DEGADIS can be used as a refined modeling approach to estimate short-term ambient concentrations (1-hr or less averaging times) and the expected area of exposure to concentrations above specified threshold values for toxic chemical releases. It is especially useful in situations where density effects are suspected to be important and where screening estimates of ambient concentrations are above levels of concern. The three most commonly used models are:

1. DEGADIS
2. SLAB
3. HEGADIS

## 4. LIMITATIONS OF AIR POLLUTANT DISPERSION MODELS

- Inadequate dispersion parameters.
- Inadequate treatment of dispersion upwind of the road.
- Requires a cumbersome numerical integration especially when the wind forms a small angle with the roadways.
- Gaussian-based plume models perform poorly when wind speeds are less than 1m/s.
- Numerical models have common limitations arising from employing the K-theory for the closure of diffusion equation. The K-theory diffusion equation is valid only if the size of the 'plume' or 'puff' of pollutants is greater than the size of the dominant turbulent eddies.
- The Gaussian puff model relative diffusion parameters are derived from very few field experiments, which limits its applicability.
- The other limitations of numerical models are large computational costs in terms of time and storage of data. It also requires a large amount of input data.

## 5. CONCLUSION

Air pollution modeling is basically mathematical modeling which determines the air pollutant dispersion into the environment. Gaussian dispersion modeling is one of the most commonly used modeling methods which computed the theoretical problems of air pollutant dispersion in terms of plotting the standard deviation and normal distribution. AERMOD is an open source Gaussian air dispersion model developed by the US Environmental Protection Agency (EPA). It has a sophisticated turbulence parameterization based on the Monin-Obukhov-theory, and has built-in models to handle complex terrain urban boundary layer (Cimorelli et al., 2005). It uses the Plume Rise Model Enhancements (PRIME) algorithm that gives a hard approximation of



complicated turbulent processes like downwash (formation of turbulent eddies due to the flowing of air pollution plume over nearby buildings or other structures in the downwind side of the building) effect near the source.

## 6. ACKNOWLEDGEMENTS

I would like to express my gratitude and respect to Prof. Indranath Sinha, Professor and Head, Department of Mining Engineering, Indian Institute of Engineering Science and Technology, Shibpur, Howrah-711103 for his resourceful guidance, valuable advice, active supervision and constant encouragement without which it would not be possible to come out with this term paper in time. I would also like to thank him for providing the departmental facilities to carry out the work.

I would also take the opportunity to express my grateful thanks to all of my friends who directly or indirectly helped me in every needy hour for completing this final term paper in time.

## 7. REFERENCES

- [1] Anon. Chapter.10 Dispersion of Air Pollutants, [online]. Available at: <http://elte.prompt.hu/sites/default/files/tananyagok/AtmosphericChemistry/> [Accessed 07 April, 2018].
- [2] Anon. Chapter.7 Air Quality Modeling, [online]. Available at: <http://www.aqbook.org/read/?page=254&action=next> [Accessed 07 April, 2018].
- [3] Atkins, Nolan. (Undated). Air Pollution Dispersion: Ventilation Factor, [online]. Available at: [http://apollo.lsc.vsc.edu/classes/met130/notes/chapter18/dispersion\\_intro.html](http://apollo.lsc.vsc.edu/classes/met130/notes/chapter18/dispersion_intro.html) [Accessed 08 April, 2018].
- [4] Briggs, G.A. (1965). A plume rise model compared with observations. J.Air Poll. Control Association, pp. 15-433.
- [5] (Boubel, et al., 1994). Fundamentals of Air Pollution (3rd ed.). Academic Press.
- [6] (Cimorelli, et al., 2004). AERMOD: Description of Model Formulation. US Environmental Protection Agency (EPA), [online]. Available at: [http://www.epa.gov/scram001/7thconf/aermod/aermod\\_mfd.pdf](http://www.epa.gov/scram001/7thconf/aermod/aermod_mfd.pdf) [Accessed 08 April, 2018].
- [7] DEGADIS Technical Manual and User's Guide, [online]. Available at: [http://www.epa.gov/scram001/dispersion\\_alt.htm](http://www.epa.gov/scram001/dispersion_alt.htm) [Accessed 08 April, 2018].
- [8] Gifford, F.A. (1957). Relative atmospheric diffusion of smoke plumes. J.Met., pp. 14-410.
- [9] Hay, J.S. and Pasquill, F. (1957). Diffusion from a fixed source at a height of a few hundred feet in the atmosphere. J. Fluid Mech., pp. 2-299.
- [10] Jr. Gotwals, Robert R. Air Quality Modeling for Teachers. The Shodor Education Foundation, Inc. [online]. Available at: <http://slideplayer.com/slide/10167234/> [Accessed 08 April 2018]
- [11] Monin, A.S. (1955). The equation of turbulent diffusion. Dokl. Akad. Naak., pp. 105, 256.
- [12] Pasquill, F. (1961). The estimation of the dispersion of the windborne material. The Meteorological Magazine, vol. 90, No. 1063, pp. 33-49.
- [13] Sutton, O.G. (1932). A theory of Eddy Diffusion in the Atmosphere. Proc. Roy. Soc. A, pp. 135-143.
- [14] Stohl A. (1998). Computation, accuracy, and applications of trajectories – a review and bibliography. Atmospheric Environment, pp. 32, 947-966.
- [15] Turner, D.B. (1994). Workbook of atmospheric dispersion estimates: an introduction to dispersion modeling (2nd ed.). CRC Press.
- [16] Walcek, C.J. (Undated). Lagrangian vs. Eulerian dispersion modeling: effects of wind shear on pollution dispersion, [online]. Available at: <https://ams.confex.com/ams/pdfpapers/36690.pdf> [Accessed 08 April, 2018].