



INTERNATIONAL JOURNAL OF ADVANCE RESEARCH, IDEAS AND INNOVATIONS IN TECHNOLOGY

ISSN: 2454-132X

Impact factor: 4.295

(Volume 4, Issue 2)

Available online at: www.ijariit.com

RFID based toll and over speed detection

Avani Gandhi

avani9659@gmail.com

Watumull Institute of Electronics
Engineering and Computer
Technology, Mumbai, Maharashtra

Kiran Yadav

kiran.itsmyworld@gmail.com

Watumull Institute of Electronics
Engineering and Computer
Technology, Mumbai, Maharashtra

Mandar Chogle

mandarchogle99@gmail.com

Watumull Institute of Electronics
Engineering and Computer
Technology, Mumbai, Maharashtra

ABSTRACT

The Proposed System consists of developing a toll and speed detection system. The method used for speed detection and toll collection at most places is traditional. These traditional methods include manually collecting toll at the toll plazas and using laser guns to detect speed of the vehicle. But manually collecting tolls can be very tedious and the speed detected by the laser guns is not always correct. Analyzing these traditional methods we have come up with a method – ‘RFID based Toll and Speed Detection’. In this method RFID tags will be given to all the cars according to their classes and will also contain basic information about the car owner and information about the prepaid balance. RFID Reader will be placed at the toll plaza. Speed detection system will be used on highways. Here the RFID Reader will be placed on highway and calculate the speed of the vehicle. If the vehicle is overspeeding, fine will be deducted directly from the balance. A real-time database will be created using Python which will keep information of the car owner and the balance to be paid at the end of one month. This RFID system at the toll plaza will avoid long queues and also save fuel which is turn is beneficial for the environment. On the highways, RFID system will help in avoiding accidents due to overspeeding vehicles.

Keywords: RFID Tag, RFID Reader, Python, database.

1. INTRODUCTION

There is always a long queue experienced at toll plazas at expressways. This wastes a lot of time and fuel. It also causes more CO₂ emission which affects our environment. Due to manual collection of toll, there is a possibility of human error, that correct toll fee is not charged depending on the class of the vehicle. There is tail gating i.e. one vehicle closely follows another vehicle to avoid the toll fee. In order to avoid tail gating, if the toll worker immediately lets down the barrier, it will crash the car bonnet and cause more chaos and traffic.

Overspeeding is the main factor that causes accidents on the highways. To avoid paying the fine for overspeeding, people many times dodge the traffic police and also try to offer bribe.

All this can be avoided by using the RFID System. RFID is Radio Frequency Identification. It uses radio-frequency to identify objects^[12]. There will be a RFID tag attached to cars. These tags will contain information which will be stored electronically in the tags. RFID tags can be active or passive. Active tags have a power source like battery and can operate at far distance from RFID reader. Passive tags obtain energy from the nearby RFID Reader. To read the information stored in RFID tags, a RFID Reader will be placed at toll plaza and at highways. A light source will be used in the process of detection of speed. The light source used will be Laser. RFID Systems are cheap and easy to install. Also lasers can work in extreme weather conditions as well.

2. EXISTING SYSTEM

There are various method implemented for effective toll collection and speed detection. Image processing is one of them^{[1][7]}. This method requires a high resolution camera to capture the image of the number plate of the car. This image is then converted into text and toll is cut from the customer's account^[1]. For speed detection^[7], moving object is identified. Temporal information such as trajectory, speed and direction of the object is extracted. A three frame difference algorithm is used to detect the speed of the vehicle. But this method has a drawback. Stickers are available in the market which is made using nanofilm technology. These stickers are ordinary numerical symbols which can be glued onto a number plate. It makes the number plate invisible to the cameras.

Another approach for controlling speed of vehicle was by Global Positioning System^[9]. This system was used only to alert the driver about the speed of the vehicle. it was designed to detect speed of the vehicle in critical zones and help the driver to drive at a safe speed. As soon as the system detects that the vehicle is overspeeding, it will alert the driver to reduce the speed.

Laser guns are also used for speed detection. The beam of laser gun is very narrow and it has to be aimed very precisely. The operator has to use a optical sight in order to aim the beam at any vehicle. Once the beam hits the vehicle it gets reflected back and this provides the speed of the vehicle. These laser guns have to be handheld and used from a stationery position. The operator has to be at very large distance to aim the laser beam and get the speed of the vehicle. Because of the large distance, the operator does not enough time for aiming. This is the biggest drawback of using laser guns.

RADAR based Zero Crossing Detector (ZCD)^[6] has been also implemented for speed detection. Speed of the vehicle is determined using the property of Doppler shift. The disadvantage of this system is that RADARs are usually expensive and less expensive RADARs can only detect the speed of the vehicle. In order to capture the image of the vehicle that is violating the speed limit, an operator is required.

3. PROPOSED SYSTEM

The proposed architecture is RFID based Toll and Overspeed Detection. Each car will be provided with a unique RFID tag which will have its unique 12 digit code. Corresponding to the RFID tag code, the vehicle number and the total toll fee and fine for overspeeding, if any, in one month will be updated in the database. This database will be created using Python. This database will be real-time and updated as soon as a toll fee or fine is charged for overspeeding. RFID reader will be placed at toll plaza and at highways. These readers will reader the RFID tag as soon as it comes in proximity of the reader.

3.1 Toll System:

When the car will arrive at the toll plaza, and comes in vicinity of RFID Reader, it will get activated. RFID reader will scan the RFID tag and the toll fee to be charged will be updated in the database along with the time at which the car arrived.

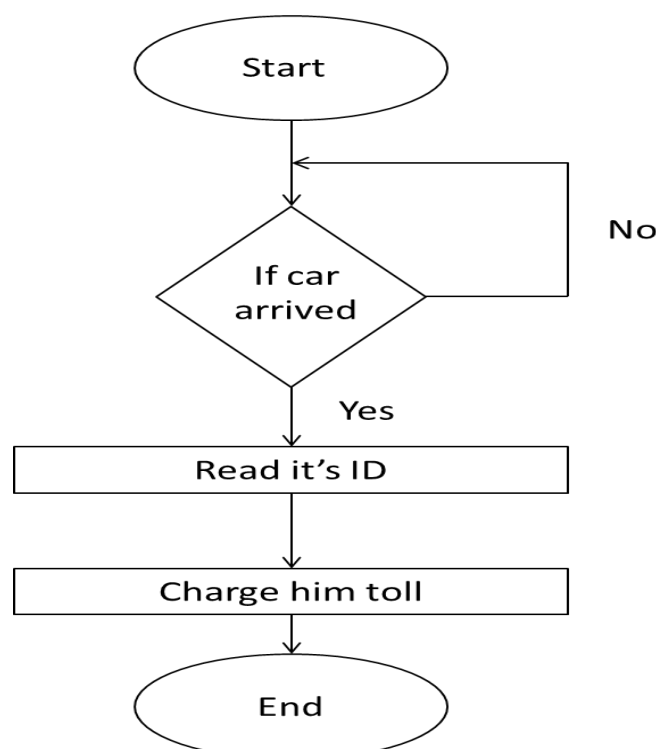

As soon as the reader will complete the scan and the toll fee will be updated in the database, the gate will open and allow the car to pass. This process happens quickly and hence the car does not have to wait at the toll plaza for the gate to open. The car can pass without stopping. This will save time of people and also save fuel of the vehicle.

3.2 Speed Detection System:

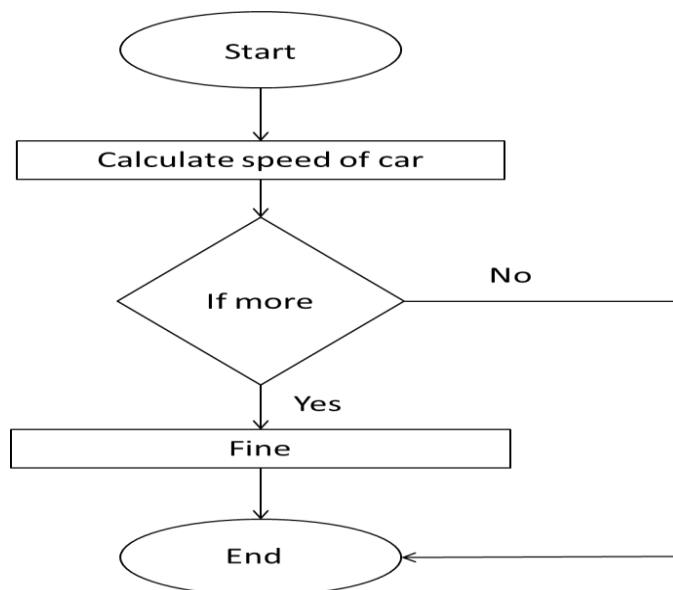

This system uses two Lasers and a RF receiver as the main components. The two lasers; Laser1 and Laser2 are placed in such a way that they are some distance apart. The distance between the two Lasers is decided according to the speed limit of the highway. Assume the distance between the two lasers to be 100m. Then the time is calculated from the equation, $Speed = \text{Distance} / \text{Time}$.

Assume the time to be 10 seconds. When the car passes through Laser1, timer starts and it will stop when the car reaches Laser2. As soon as it crosses Laser2, the speed of the car between these two lasers will be calculated. If the time taken to cross Laser2 is more than 10 seconds, it means that the speed of car is below the permissible speed limit. If the time taken to cross Laser2 is less than 10 seconds, it means that the car is overspeeding and the RF receiver will become active and will read the RFID tag on the vehicle and get the RFID tag code. Corresponding to that code, the vehicle number of the car will be obtained from the database. The fine that will be charged will get updated in the database.

At the end of one month, the total toll fee and the overspeeding fine has to be paid by the car owner.

As paying the fine for violating the speed limit will become compulsory, people will be more careful about the car speed on highways which in turn will lead to less accidents.

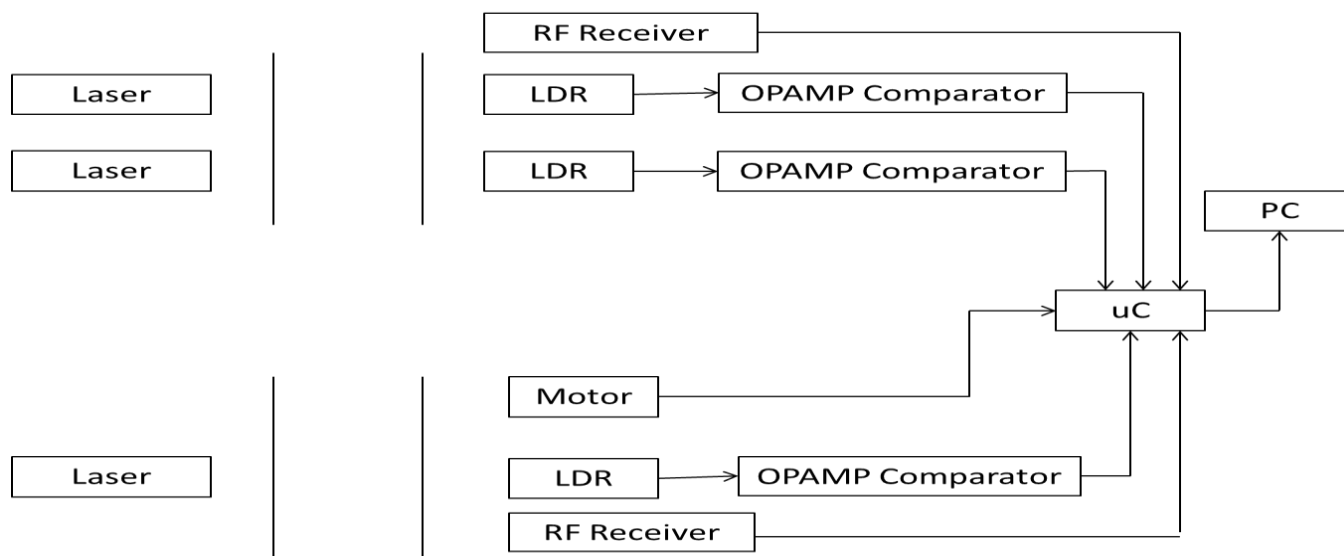

Fig-1 Block Diagram of Toll and Overspeed Detection System

4. CONCLUSION

In this paper, we present an easy way of collecting tolls and detection of speed. This system is convenient, effective and easy thereby improving the performance of toll collection and speed detection. As the name suggests, this system uses RFID tag and a RFID reader. Database will have all the information regarding the class of the vehicle, owner information and information about amount to be paid at the end of each month. This database will be created using Python and will be real time.

This project will help in reducing manual labor, traffic at toll plazas and fuel wastage. It will also help in reducing accidents on the highways.

5. FUTURE SCOPE

As the proposed system has all the information saved in database, it can be used as anti-theft. If a car is stolen, the registration number of the car can be updated in the database. If this car passes any toll plaza, a silent alert can be given to the toll operator who can inform the police about the stolen car.

It can also be used at Pay and Park. Here the RFID tag of the car can be scanned and the timer will be turned on. When the cars exits, the timer will turn off and the parking fee can be collected accordingly.

6. ACKNOWLEDGEMENT

The authors gratefully acknowledge Prof. Vrushali Purandare from Watumull Institute of Electronics Engineering and Computer Technology, for her guidance in the project and providing encouragement for this work.

7. REFERENCES

- [1] International Journal of Research Studies in Computer Science and Engineering (IJRSCSE) Volume. 1, Issue 3, July 2014
- [2] International Journal of Research Studies in Computer Science and Engineering (IJRSCSE) Volume. 1, Issue 3, July 2014
- [3] International Journal for Research in Applied Science and Engineering Technology (IJRASET) Volume 3, Issue 5
- [4] IOSR Journal of Computer Engineering (IOSR-JCE) Volume 9, Issue 2
- [5] International Journal of Scientific and Research Publications, Volume 4, Issue 6, June 2014
- [6] International Journal of Electrical, Electronics and Data Communication, Volume-1, Issue-9, Nov-2013
- [7] International Journal of Computer and Electrical Engineering, Volume 3, no. 6.
- [8] International Journal of Computer Science and Mobile Computing, Volume 4, Issue 4
- [9] International Journal of Innovative Research in Electrical, Electronics, Instrumentation and Control Engineering Vol. 2, Issue 8, August 2014
- [10] International Journal of Engineering Trends and Technology (IJETT) - Volume4Issue5- May 2013
- [11] <http://www.indiantollways.com/wp-content/uploads/2011/12/Presentation-by-Mr.-Sachin-Bhatia-on-ETC-in-India.pdf>
- [12] <http://www.centrenational-rfid.com/definition-of-rfid-article-71-gb-ruid-202.html>