



# INTERNATIONAL JOURNAL OF ADVANCE RESEARCH, IDEAS AND INNOVATIONS IN TECHNOLOGY

ISSN: 2454-132X

Impact factor: 4.295

(Volume 4, Issue 1)

Available online at [www.ijariit.com](http://www.ijariit.com)

## Design of Automatic Sorting Machine

Mangesh Shashikant Bidkar

[bidkarmangesh@gmail.com](mailto:bidkarmangesh@gmail.com)

DILKAP Research Institute of Engineering and  
Management Studies, Neral, Tal-Karjat, Raigad,  
Maharashtra

Chandraprakash M. Zode

[zode\\_chandu@rediffmail.com](mailto:zode_chandu@rediffmail.com)

DILKAP Research Institute of Engineering and  
Management Studies, Neral, Tal-Karjat, Raigad,  
Maharashtra

### ABSTRACT

*The automatic sorting system has been reported to be complex and a global problem. This is because of the inability of sorting machines to incorporate flexibility in their design concept. Automation is a preferred for faster and precise operations as compare to manual operation. This paper provides a mean of simple yet effective fixed type of automation for sorting the products. Two products identical in shape and size are sorted out automatically on the basis of drilled or undrilled product. LED and photo transistor arrangement is used for hole detection. Vertical zigzag conveyor is employed instead of usual flat belt conveyor in order to utilise gravitational force as a driving force for feeding the products. 8051 Microcontroller is used for controlling the sorting mechanism by using program or coding.*

*The cost of project is nearly negligible as it is made from the waste except electrical components used for the project. Sincere efforts are taken to set an example of an inexpensive, reliable and easy to manufacture automated machine. The Paper focuses on the aspect of sorting mechanism with microcontroller programming and the automation tasks and solutions is obtained.*

*The proposed developed model of this research could be adopted at any institution or industries, whose practices are based on mechatronics engineering systems. This is to guide the industrial sector in sorting of object and teaching aid to institutions and hence produce the list of classified materials according to the enabled sorting program commands.*

**Keywords:** Phototransistor, Vertical Zigzag Conveyor, Microcontroller.

### 1. INTRODUCTION

#### 1.1 General Introduction

In the present world, there are plenty of scientific innovations and sophisticated technologies that has simplified human life and raised the standard of living. Scientists are busy with the research and development works. Day-by-day scientists come up with better ideas that make the life of common man more automated. As an attempt to develop an automated set-up in whatever area possible which would further simplify human life and make it easier, we ended up with the very relevant area of concern - sorting.

In various other places where sorting comes into play predominantly are airports, seaports, small-scale industries, super markets, etc. But due to the restricted reach of automation in sorting in these sectors, the thought about automated sorting in such fields ought to be considered with much importance. Thus, to extend the advantages of automated sorting in large-scale sectors to the above mentioned sector, a notion of automation has been thought to implement in small-scale sectors.

With this in mind, we set out for a search throughout to gather more ideas and simpler technologies to implement to realise our notion. Thereafter, we thought of selecting a barcode sorted technology since most of the products are with a barcode on them. This would further simplify our job, hence, giving clarity on how the products need to be sorted. The gadgets required for the implementation of this system were also easily available and without much complicated circuitry, the system could be set up. After a detailed enquiry about the scope and implementation of our system, we were able to collect two papers based on sorting but using different criteria for sorting.

### 1.2 Problem Statement

The problem statement for the project is to create the electronic material handling system which can be used to reduce the efforts of workers as well as to reduce the time spent in inspection of the components, during their manufacturing. It also reduces the efforts in transferring the components manufactured to another workstation. The most apparent reasons that are associated in installing of automatic system in industry are,

- i. Saving Man Power
- ii. Improved Quality and Efficiency
- iii. Increase consistency and Flexibility

### 2. OBJECTIVES

The system that we have come up with aims to reduce the human effort and hence, the consequent errors. Moreover, the system helps tackle the tedious sorting process by mere barcode scanning done on the selected products. It, furthermore, promotes speed and reliability of sorting.

### 3. PROCEDURE

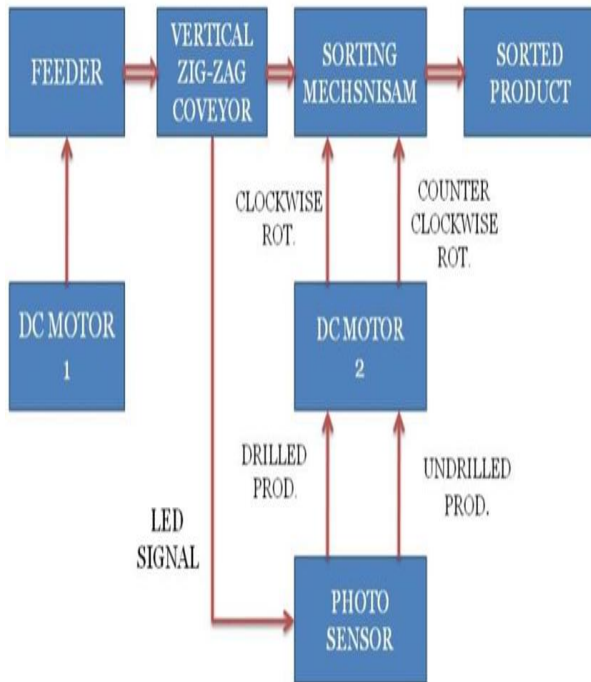

Figure-1: Block Diagram of Automatic Sorting Machine

### 4. METHODOLOGY

Project was conceptualized as shown in diagram. The basic aim was to make a machine with both mechanical and electronics systems with minimum cost and effective design in order to achieve an unconventional automation system

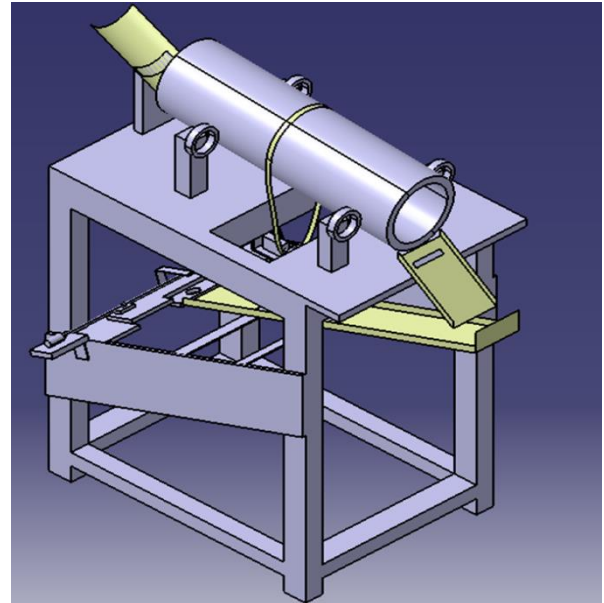

Figure-2: Setup of Automatic Sorting Machine

The products are to be fed through the sheet metal feeder to a vertical zigzag conveyor. Dc motor 1 is used for feeding system so as to provide smooth flow of products. Once products are passed through conveyor they are collected in a C-collar where hole detection system is placed to check for drilled or undrilled product. Corresponding signal was transmitted to 8051 microcontroller from where it was further transferred to L293D DC motor driver according to programming dumped in microcontroller. Motor driver drives the DC motor 2 in clockwise or counter clockwise direction and product is sorted accordingly.

### 5. CIRCUIT DIAGRAM OF IR SENSOR

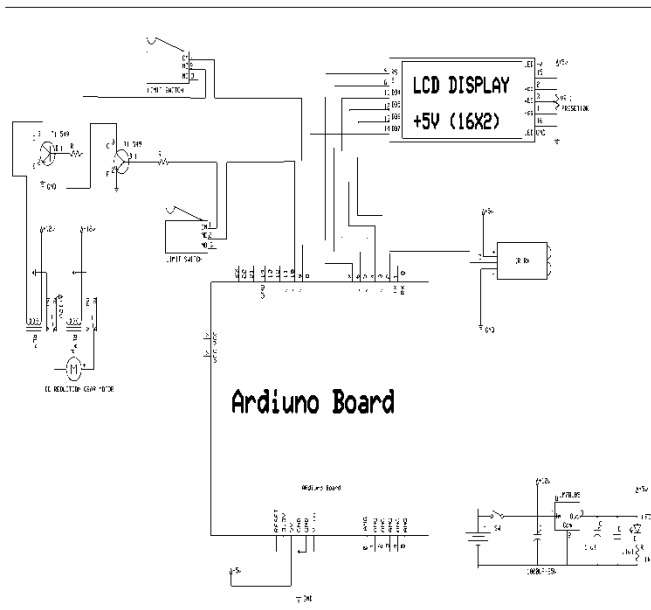

Figure-3: Circuit Diagram of Sensor

### 6. WORKING

This is how the Automatic Sorting Machine works:

1. The plates are fed into the machine by hand.
2. The roller aligns the plates to fall in the plate magazine one by one. When the plate reaches the bottom of the sorter, it triggers a micro switch.
3. When the switch is on, the LED turns ON.
4. If the plate has a hole the Photocell will receive more light and the motor will rotate to one side.
5. If the plate doesn't have a hole the Photocell will receive less light and the motor will rotate to the other side.

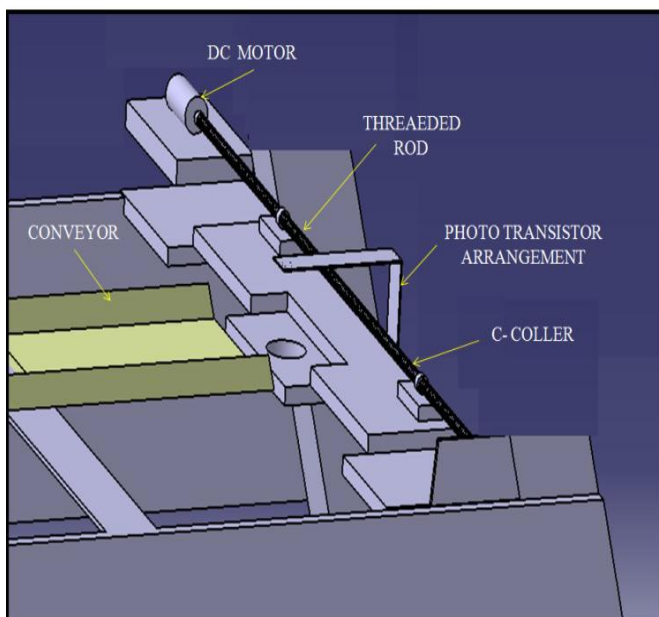

Figure-4: Sorting Mechanism

### 7. CONCLUSION

The automatic sorting machine using conveyor belt is basically useful for sorting the products in the industry specifically large scale industries where mass production is carried out. The machine also reduces the efforts of the workers by reducing the time spent for material handling. The application area of this machine is very wide in industries where automation is built. Thus our aim to achieve realistic and practical sorting with the observation that changes in the shape of square plate or any shape inside the plate and this can be used to detect the dimensional variation by using very cheap and reliable sensor designed as the **automatic sorting machine** is achieved.

### 8. REFFERANCES

- (1) "Automatic Sorting Machine Using Delta PLC", International Journal of Innovative Research in Advanced Engineering (IJIRAE) ISSN: 2349-2163 Volume 1 Issue 7 (August 2014)
- (2) www.wikipedia.com
- (3) www.robotricks.com
- (4) Alexandrov, Material handling equipment, central books limited, 1981



**First Author Name**  
**MANGESH SHASHIKANT BIDKAR**  
**Designation: Student**