



INTERNATIONAL JOURNAL OF ADVANCE RESEARCH, IDEAS AND INNOVATIONS IN TECHNOLOGY

ISSN: 2454-132X

Impact Factor: 4.295

(Volume3, Issue6)

Available online at: <https://www.ijariit.com>

Power Quality Enhancement and Harmonics Reduction in Non Linear Loads using Vienna Rectifier

D. Venkatesan

Assistant Professor

CK College of Engineering and Technology, Cuddalore, Tamilnadu.

saransan1977@gmail.com

Abstract: *This project is designed to improve power quality and to reduce current type harmonics distortion and power factor correction in domestic non linear loads with the help of Vienna rectifier (three phase three level three switch pulse width modulation rectifier). Harmonics distortion in electric distribution system is increasingly growing due to the widespread use of non linear loads. Most modern power supplies are non linear load which contains electronic devices that do not conduct current over the full cycle of the applied voltage and so introduce harmonics in to the power network. Hence improve the power quality and gives unity power factor from supply side. The paper compiles and discusses the harmonics reduction method, power factor correction and power quality improvement technique.*

The simulation and experimental results demonstrate that the proposed system reduce current type harmonics distortion and power quality improvement in efficient way.

Keywords: DC-AC converters, VIENNA rectifier, DC-DC converters

1. INTRODUCTION

AC-DC converters find application in everyday-life as a front-end to DC-DC and DC-AC converters. In low power with low cost applications, the AC to DC conversion is very often merely a diode bridge rectifier with capacitor voltage filter. However, bridge rectification inherently draws non-sinusoidal current from the mains, which make it inadequate for high power applications due to the strict regulations on conducted EM (electromagnetic) energy, as well as the high current stress on components. For high power applications, the sinusoidal current must be actively shaped by using either a boost type front-end converter or by complex EM filtering at the input. Research and development of the latter has ceased mainly due to the cost and size associated with EM filters.

For medium power converters, a single-phase input is adequate and the front-end is usually a single-switch non-isolated boost topology that boosts the unregulated mains input to a voltage higher than the rectified line voltage. The switch is controlled in such a manner that the current drawn from the mains source is in phase with the mains voltage (effectively sinusoidal). The zero phase angle, between the mains voltage and the current, translates into a high power factor which, in turn, ensures that the source is not loaded reactively. For higher power outputs it is advantageous to use a three-phase input to lower the component stresses and to reduce component size (e.g. the filter capacitor). The three phase active rectifier is based on the concept of the single-phase active rectifier and draws sinusoidal current from all three phases.

Controlled rectifiers are classified as being either isolated or non-isolated. For three-phase rectifiers, the non-isolated topologies are derived from the isolated topologies with the magnetic coupling (and thus isolation) achieved by

the use of split inductors. However under most circumstances the large, low frequency output voltage ripple is intolerable for direct use.

A DC-DC converter is usually used as second stage to the AC-DC converter and isolation is achieved in the second stage. For this reason it is unnecessary to use an isolated AC-DC front-end converter. Currently research is done on three topologies of three-phase active rectifiers. The first topology is a one quadrant, three-phase, single-switch, two-level converter. This topology shapes the input current using a single switch and the output is a single positive voltage. The second topology is a four quadrant, three-phase, six-switch, two-level converter with, as the operation implies, bi-directional current flow capability. Six switches are used to shape the input current and the output is also a single positive rail.

The third topology is a one quadrant, three-phase, three-switch, three-level topology. Input current waveforms are controlled by three switches and the output is a positive split DC rail. The third topology mentioned is also known as the VIENNA rectifier and most of the current research focuses on this type of rectifier and variants.

2. SOURCES OF POOR POWER QUALITY

Sources of poor Power Quality are listed as follows:

- Switching Power supplies
- Adjustable –speed drives
- Arc furnaces
- Electronic Fluorescent lamp ballasts
- Lightning Strike
- L-G fault
- Non- linear load
- Starting of large motors
- Power electronic devices

3. NEED OF POWER QUALITY

There is an increased concern of power quality due to the following reasons:

1. New-generation loads that use microprocessor and microcontroller based controls and power electronic devices, are more sensitive to power quality variations than that equipment's used in the past.
2. The demand for increased overall power system efficiency resulted in continued growth of devices such as high-efficiency adjustable-speed motor drives and shunt capacitors for power factor correction to reduce losses. This is resulting in increasing harmonic level on power systems and has many people concerned about the future impact on system capabilities.
3. End users have an increased awareness of power quality issues. Utility customers are becoming better informed about such issues as interruptions, sags, and switching transients and are challenging the utilities to improve the quality of power delivered.
4. Most of the networks are interconnected these days. Integrated processes mean that the failure of any component has much more important consequences.

4. OVER VIEW OF VIENNA RECTIFIER

There is growing awareness about line pollution and deteriorating power factor due to all pervading inductive and non-linear loads. Utilities are as much concerned as the users. Passive power factor correction techniques are neither convenient nor economical; they need bulky components and are not adaptive to changing needs. Although many solutions were offered for power factor correction. As all high Power equipment's derive electrical power from supply mains, incorporating an active Phase PFC front end can contribute significantly in improving overall power factor and reducing line pollution. In addition to lowering power bill to the consumers, improved power factor also contributes towards conservation of energy and helps in reducing air pollution, by virtue of less fossil fuel required for generating same amount of electrical power [16]. Thus Vienna rectifier gives better power factor and other resultant effects are lower I²R losses, steadier terminal Voltages, released system capacity and reduced cable & switchgear sizes. Active PFC front ends also help meet the IEEE 519-92, IEC-555 and European EN 61000-3-2 standards for allowable harmonic contents of mains.

Vienna rectifier gives various advantage application and limitation they are-

A. Advantages of Vienna Rectifier-

- 1) It's a boost type PFC with continuous sinusoidal input current and unidirectional power flow.
- 2) It needs only active switches, i.e. MOSFETS.
- 3) It is Operational even in presence of unbalanced mains or only two phases.
- 4) Total switching losses are reduced by a factor of six, assuming switching Frequency below 50 KHz.
- 5) Any malfunction in control circuit does not manifest itself in short circuit of output or PFC front end.
- 6) Sinusoidal input currents with Power Factor = 0.997, THD<5% and overall efficiency > 97% are obtainable with current designs.

B. Applications of Vienna Rectifier-

A number of industrial, telecom and computing equipment's are used Salient amongst them are

- 1) A.C. and D.C Drives.
- 2) Telecommunication Power Supplies.
- 3) Uninterruptible Power Supplies.
- 4) Air Conditioning Units.
- 5) Computer Installations.
- 6) Power supplies for all industrial uses such as welding, surface treating, motion .control, large appliances and process control.
- 7) R.F. Transmitters and Radar Transmitters and repeater stations.

C. Limitation of Vienna Rectifier

- 1) Unidirectional power flow.

5. METHODOLOGY

Vienna rectifier is three switching, three phases and three level rectifiers in the power factor correction. In AC voltage and DC voltage and input line current is sinusoidal hence unity power factor is obtained. Vienna rectifier is used to a power factor correction with the three MOSFETs switches are used to switching loss is reduced. The Vienna rectifier deals with the reduction and switching losses are reduced in this method.

6. VIENNA RECTIFIER

The Vienna rectifier consists of three switches MOSFETs; it converts the AC voltage into control output voltage. It can also provide sinusoidal input currents and control output voltage. The AC voltage from the three phase generator is given to the Vienna rectifier. The current flows through the three MOSFETs and the capacitors in the fully charged it. The phase current rises, through MOSFETs, during that pulse period, charge the capacitor. When the MOSFETs turn off condition, current through the diode upper or lower depending on direction of the current flow. By adjust the width of the pulse that turns ON the MOSFETs, corresponding line current is forced to be sinusoidal and in phase with the Voltage. When the MOSFETs is turned ON the corresponding phase is connected the line inductor, to the center point between the two output capacitors.

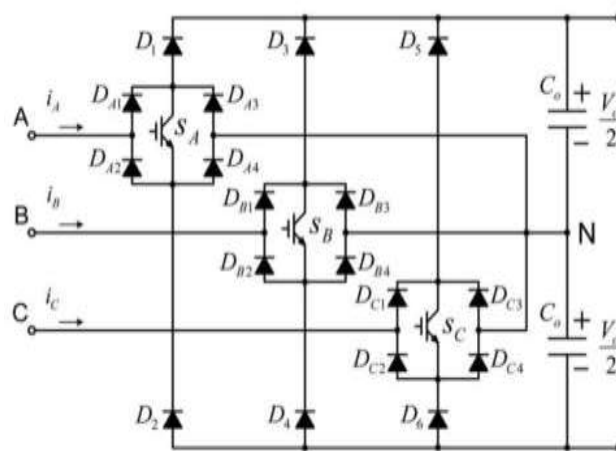

Fig: 1 Vienna Rectifier

6.1 Objective of Vienna Rectifier

Three phase of input conversion and its Particular for a unity power factor operation. In figure-1 ACR, ACY and ACB are 420V, 50 KHz, Three Phase sinusoidal input Voltages are -Vdc and +Vdc are the output connected to load. There are three switches, corresponding to each phase M1, M2 and M3. The switches are continuously at around 50 KHz. The duty the current from each phase of sinusoidal and in phase with the corresponding input Voltage unity power factor.

6.2 Description

In Vienna Rectifier configuration as shown in figure-1, the output capacitor is split into two parts as two equal value capacitors C1 and C2 are connecting the series level source. Across the output capacitors the -Vdc and +Vdc are develop the three Phase level output. A switch for each phase is connected, such that when —ON , it connecting the phase to the center mode of C1 and C2 through a series with inductance. The common of C1 and C2 will have Voltage with sine wave shape, having three times output voltage frequency and its amplitude will be phase voltage.

6.3 Switching Mode of Vienna Rectifier

The Vienna rectifier has three switches, (ON\OFF) of the phase current and voltage in each phase will be determined. So, the phase voltage is depends upon the direction of phase current and switch position of the switch (ON/OFF) and the polarity of the current in each phase determine the rectifier voltages at any instant of operation. In order to discuss the operation principles of the rectifier, in Phase A is explained at the Phase B and Phase C. If the current is positive, and the switch Ta is off, the current flows through diode, and the voltage between the converter A and the DC midpoint M is DC/C2. The conduction path for this case is illustrated in Figure-4.3 2(i). If the polarity of the line current is positive, and the switch is on, the voltage is 0, in which the conduction path in Figure-4.3 2(ii) Similarly, the voltage can be determined in other states as illustrated in Figure-4.3 2(iii) and (iv).This operating of principles also can apply for an Phase B and phase C to determine the VBM and VCM.

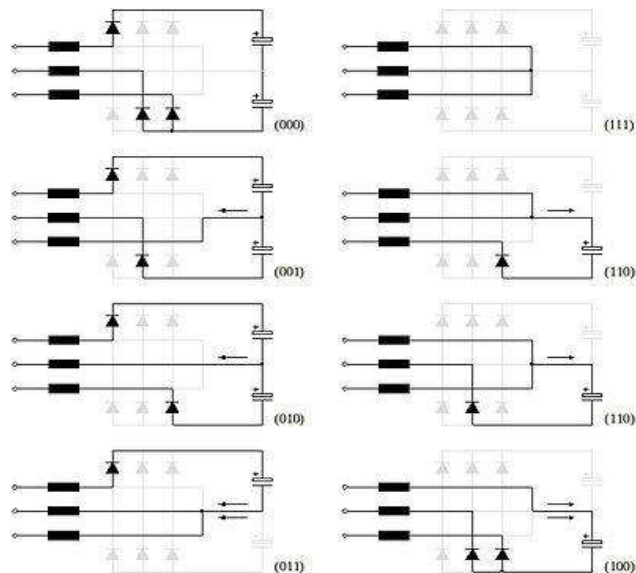

Fig: 2 Switching Of Vienna Rectifier

Conduction states of the Vienna Rectifier, for $i_a > 0$, $i_b, i_c < 0$, valid in a 60D sector of the period T1 S_a, S_b , and S_c characterize the switching state of system. The arrows represent the direction and value of the current midpoint i_o

7. SIMULATION AND RESULT

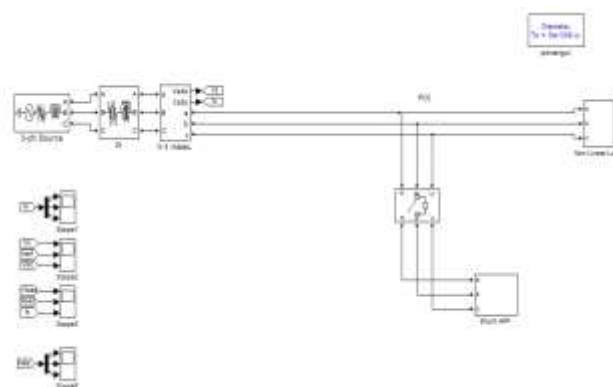

Fig 3. Simulation Diagram

In this simulation diagram when the non linear load is connected to the three phase source and to measure the input source voltage and current by using scope 1. To measure the source voltage in scope 2 and also measure the output of Vienna rectifier (i.e.) DC current is measured in scope 2. In this scope 2 we also measure the filter current of the power active filter. In scope 3 we measure the load voltage, load current. Here we will eliminate current type harmonics with the help of Vienna rectifier with using shunt active power filter.

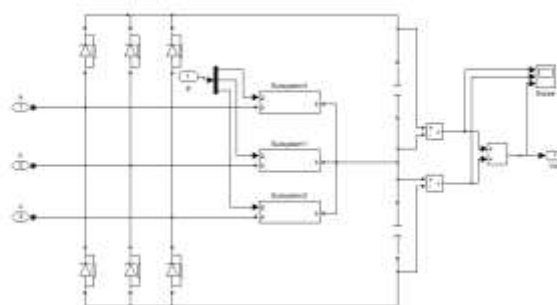

Fig 4. Vienna Rectifier

This is the simulation diagram of Vienna rectifier. In this simulation diagram when the three phase AC supply is given and it convert it into dc without producing harmonics and also reduce harmonics in source side.

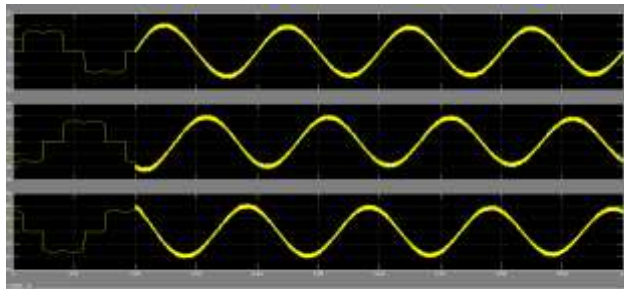

Fig 5 Output of three phase source after distortion and pure sine wave

In this simulation result shows that the output of three phase source current, current harmonics distortion at the time of non linear load connected to the source. When the distortion occurs at the source side it will affect the supply side. so we use Vienna rectifier and also use power active filter to reduce current type harmonics distortion in supply side. After using of filter circuits we got pure sine wave to supply side.

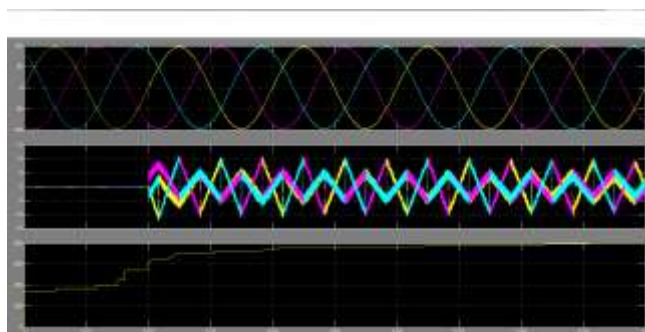

Fig 6 Outputs Source voltage, filter current, DC current

In this simulation results shows that the three phase source voltage of R, Y, B phases and distortion current near the filter circuits. The output of rectifier is DC so the filter circuits reduce the current type harmonics both supply and output side.

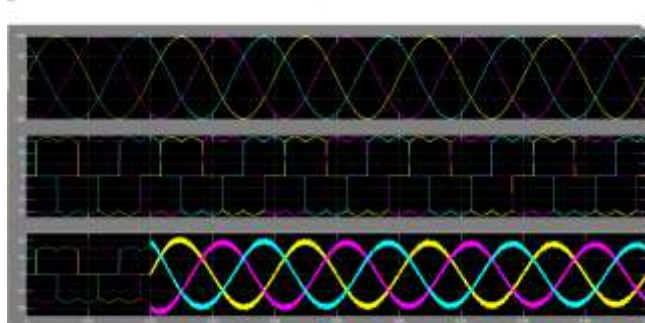

Fig 7 Voltage, distortion current waveform, after reducing current type harmonics

CONCLUSION

In this project, power quality enhancement, with the help of (three-phase three-switch three-level) Vienna rectifier has been theoretically investigated in small prototype model and also it was proved that the harmonic distortion has been reduced in the non linear loads. Simulation results shows that the output voltage ripples were reduced and also it was observed that very low input current harmonics at output and unity power factor.

Hence it was concluded that the proposed system will address the highly distorted Voltage and current at the consumer's end. This will avoid the distortion power in the distribution System. This will enable the electrical distribution system to embrace a greener future more potently.

REFERENCES

- [1] Roger .C Dugan, Electrical power system quality. Mc Graw-Hill, second edition
- [2] Bachir Kedjar, Hadi Y. Kanaan, Kamal Al-Haddad “Vienna Rectifier with Power Quality Added Function” IEEE TRANSACTIONS ON INDUSTRIAL ELECTRONICS, VOL. 61, NO. 8, AUGUST 2014
- [3] Vimla Patel, Shivendar Singh Thakur “Simulation of Vienna Rectifier to Enhance Power Quality By Reduce THD” International Journal of Engineering and Innovative Technology (IJEIT) Volume 2, Issue 9, March 2013
- [4] C. Venkatesh, D. Srikanth Kumar, D.V.S.S. Siva Sarma and M. Sydulu “Modelling Of Nonlinear Loads and Estimation Of Harmonics in Industrial Distribution System” Fifteenth National Power System Conference, IIT Bombay, December 2008
- [5]Purushothama Rao Nasini, Narender Reddy Narra and Santosh .A “Modeling And Harmonics Analysis Of Domestic/Industrial Loads” International Journal Of Engineering Research and Applications, Vol.2, Issue 5, September- October 2012,PP.485-491.