



INTERNATIONAL JOURNAL OF ADVANCE RESEARCH, IDEAS AND INNOVATIONS IN TECHNOLOGY

ISSN: 2454-132X

Impact factor: 4.295

(Volume3, Issue4)

Available online at www.ijariit.com

Recovery of RF Signal from Modulated Optical Signal

Akshata Gudihal

Dayananda Sagar College Of Engineering
akshataa75@gmail.com

Saravana Kumar

Dayananda Sagar College Of Engineering
kumar1380@gmail.com

Abstract: In the previously proposed system, Radio frequency signal was transmitted through RF system. But the system had some disadvantages like non-coherence and system was not efficient. This was overcome by using RF to optical domain converter. But that signal has to be recovered by converting the optical signal back to RF signal. This can be done by this system i.e. Optical to RF converter which is having photodetector, TIA, and LNA. Here the modulated optical signal is detected by using photodetector, which detects the light signal and converts it to the current signal. This current signal is converted to a voltage signal and then required amplification is provided by using an LNA. Hence this system is a compact and efficient system which is to provide a high-speed optical to RF conversion.

Keywords: RF, PD, LNA, TIA, PSoC.

1. INTRODUCTION

From the last few decade, the use of FO (fiber optic) cable replace the old coaxial cables and has many applications due to advances in fiber optic technology. It is meant to inform an experienced in-building (DAS) wireless system designer familiar with terms of fibre optic, their specifications, and the devices as they would be applied in a radio frequency (RF) system design. There is some generalization used that help in the introduction to the Fiber optics. The specific specifications that are used here are based on manufacturers published specifications. (1)

1.1 RF APPLICATIONS OF FIBER OPTIC SYSTEM

FO cables are the one which are having very small losses compared to coaxial cables. With RFoF distances of many miles being practical because the new tools that are developed to solve difficult RF distribution challenges that would normally be impractical using coaxial cables. FO cables usually do not 'leak' or couple RF signals makes them ideal when routing through noisy RF environments or running long lengths parallel to other FO or RF cables. The lack of electrical conductivity may also be attractive in some applications, such as electric utilities. Fiber optic cables can be much smaller and lighter weight than corresponding RF cables and are usually non-metallic, making installation and routing much simpler. (1)

1.2 FIBER OPTIC SYSTEM COMPONENTS

The main components of an RF - FO system consists of:

- (1) FO cable
- (2) FO Transmitters
- (3) FO Receivers.

The receiver and transmitter components may be single small stand-alone 'transceivers' or rack mounted units containing several fiber transceivers. RF to the Fiber equipment locates at the base station or signal booster end is said to be as the "head-end" of the system. RF to Fibre equipment is located at the far end of the FO cable is called as the "remote-end" or simply a "remote". (2)

1.3 LINK BUDGET

The below figure 1.2 shows link budget calculation of proposed system.

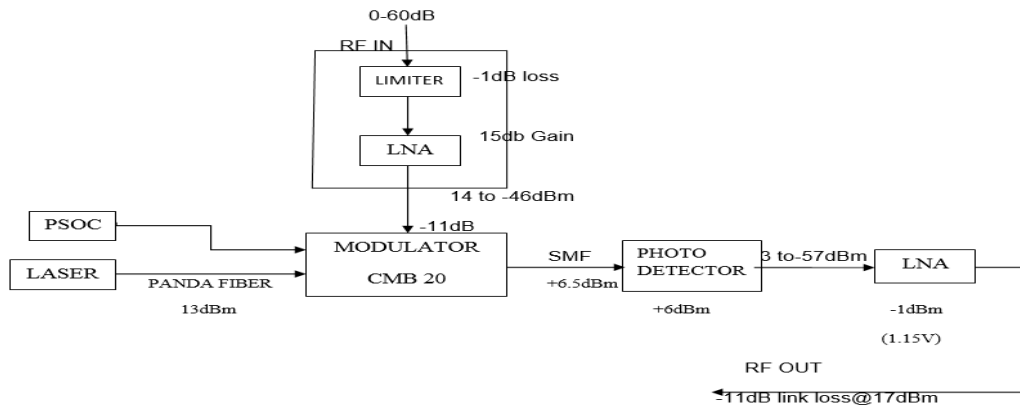

Fig 1.2: Link budget calculations

The link budget is nothing but calculating the overall performance of the system based on given specification. Usually, the RF input will range from 0dB-60dB. By using limited there will usually 1dB of loss. By using the low noise amplifier the up to 15dB gain can be obtained and output of laser will be of 13dB. The Laser output is given as input to the Modulator and output of modulator will be +6.5dB. The detector will vary from 3dB to -57dB hence, the link loss will be of -11dB at 17dB.

2. SOFTWARE REQUIREMENTS

2.1 OrCAD TOOL

OrCAD is one type of proprietary software tool suite used primarily for electronic design automation (EDA). OrCAD Capture is a schematic capture application, and it is also a part of the OrCAD circuit design suite. In-built simulation features are not present in Capture, but exports netlist data for the simulator, OrCAD EE. Capture can export a hardware description of the circuit schematic to Verilog or VHDL, and the netlists to the circuit board of designers such as OrCAD Layout, Allegro, and others. Component information system (CIS) is included in the Capture that links component package footprint data or simulation behaviour of the data, which is having a circuit symbol in the schematic. (4)

2.2 OPTISIM

Optisim is a Java-based open source software for building and simulation of models according to System Dynamics methodology. It was developed in comparison to currently available commercial tools, contains advanced numerical procedure which is much more accurate than traditional Euler or Runge-Kutta ones. As a result, Optisim allows to a model wider range of systems. Another important feature is the way it communicates with IDOS optimizer which gives the possibility to use optimal control theory to search optimal trajectories in System Dynamics models. Due to the above, there is a proposition to define the Extended System Dynamics methodology which consists of new tools and techniques not accessible yet in classical System Dynamics. (5)

3. IMPLEMENTATION DESIGN

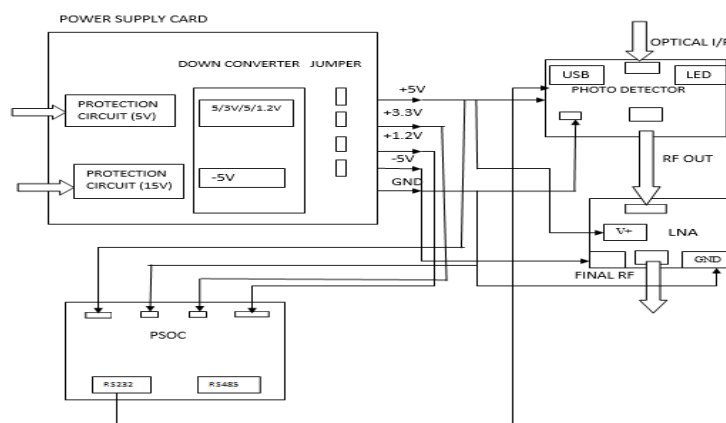

Fig 3.1:Chassi

The above figure 3.1 shows the implementation of chassis. Chassis is a physical frame or a structure of the multi-component device. Here it consists of power supply unit, controller, a photodetector and the low noise amplifier. The detailed explanation of chassis components is described below.

3.1 PROTECTION CIRCUIT

Figure 4.2 shows the 5V power supply circuit used for the proposed system.

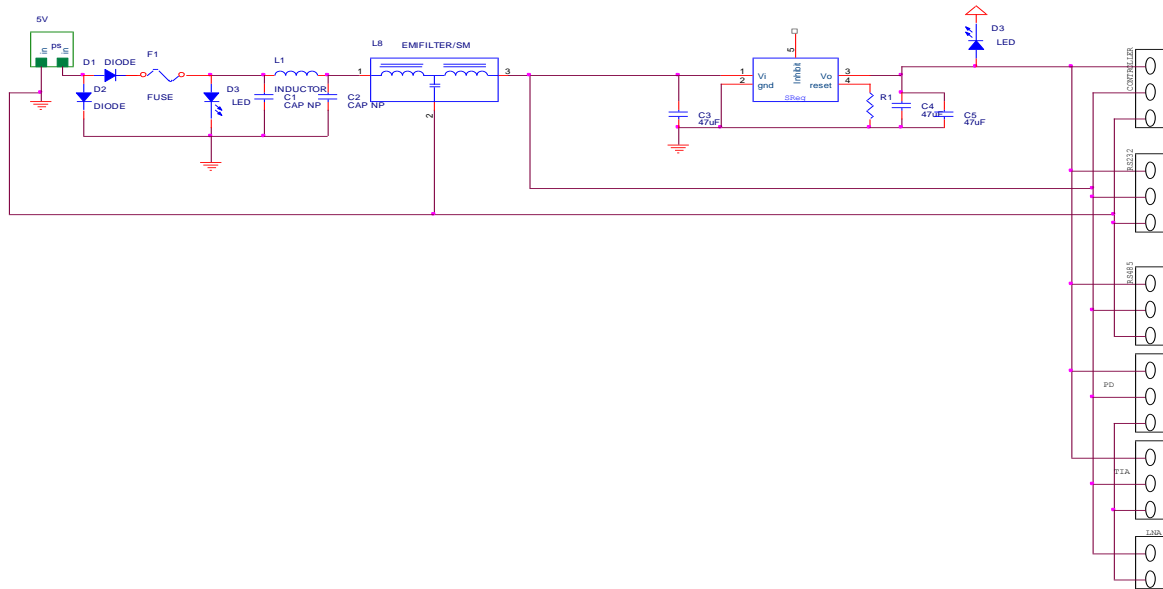

Fig 3.2: Power Supply

The above power supply unit consists of

1. BAT54 SERIES DIODE
2. FUSE
3. PI FILTER
4. EMI FILTER
5. FERRITE BEAD
6. SWITCHING REGULATOR

3.2 3 V to 5.5 V Low-Power True RS-232 Transceivers

The control and data circuit used here only operates in one direction that is, signaling from a DTE to the one that is attached DCE or vice versa. Because of each transmit data and receive data are having separate circuits, the interface can also operate in a full duplex manner, with supporting concurrent data flow in both directions. Here the standard will not define the encoding of character within the data stream, or also the character framing.

The MAX3232 is transceivers that have a proprietary very low dropout transmitter at the output stage with enabling true RS-232 performance from a 3.0V to 5.5V supply which is having dual charge pump. The devices require small four 0.1μF external charge pump capacitors. The MAX3232 will assure so that it can run at a high data rates of 120kbps while maintaining RS-232 at the output levels. The MAX3232 has 2 receivers and 2 drivers. The following figure 3.6 shows schematic of the RS232 transceiver and Table 3.3 describes the pin description.

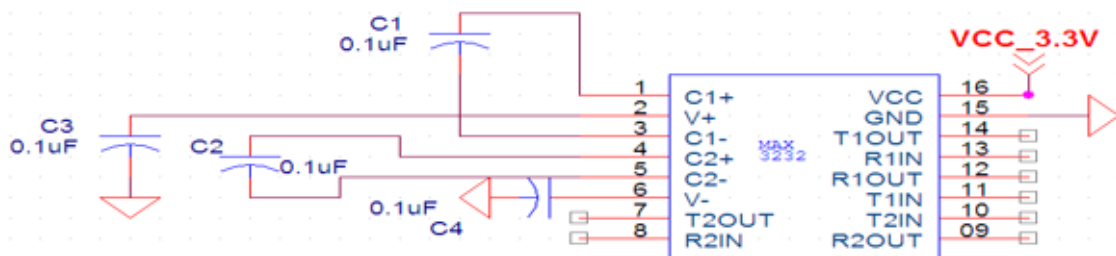

Fig 3.6: Schematic of RS232

3.3 3.3V, High-Speed, RS-485/RS-422 Transceiver

The MAX3362 high-speed, low-power transceiver for RS485/RS422 communication which operates from a single +3.3V power supply. Here device mainly contains one differential transceiver which is consisting of a line driver and receiver. The transceiver will operate at data rates up to 20Mbps, which has an output skew of less than 6ns. Here the receiver and driver propagation delays are guaranteed to be below 50ns. By this low skew and fast switching make the MAX3362 ideal for multi-drop clock/data distribution applications. The output level is assured at +1.5V with a standard 54Ω load, compliant with RS-485 specifications. The

transceiver draws a supply current of 1.7mA when fully loaded or unloaded with the drivers disabled. Figure 3.6 shows schematic and table 3.4 shows pin description of the RS485 (6)

SCHEMATIC

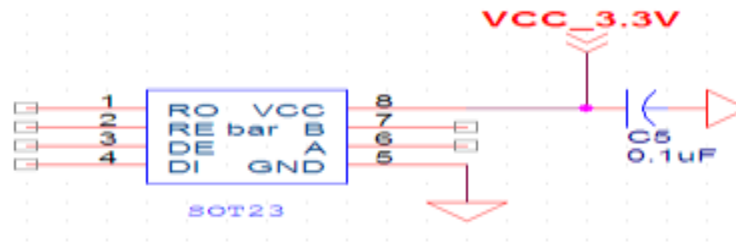

Fig 3.6: Schematic of RS485

3.4 PSoC

PSoC resembles an ASIC block that may be assigned to a wide range of functions and interconnected on-chip. There is no special manufacturing process required for creating the custom configuration only start up code that is created by Cypress' PSoC Designer (for PSoC 1) or PSoC Creator (for PSoC 3/ 4 / 5) IDE. PSoC resembles an FPGA for which the power-up must be configured, but the configuration occurs because of loading instructions from built-in Flash memory. A PSoC mainly appear like a microcontroller combined with a programmable analog and PLD. PSoC consists a specific array of blocks that is configurable and is real system level which provides solution in a single chip for memory, MCU, digital and analog peripheral functions. (6)

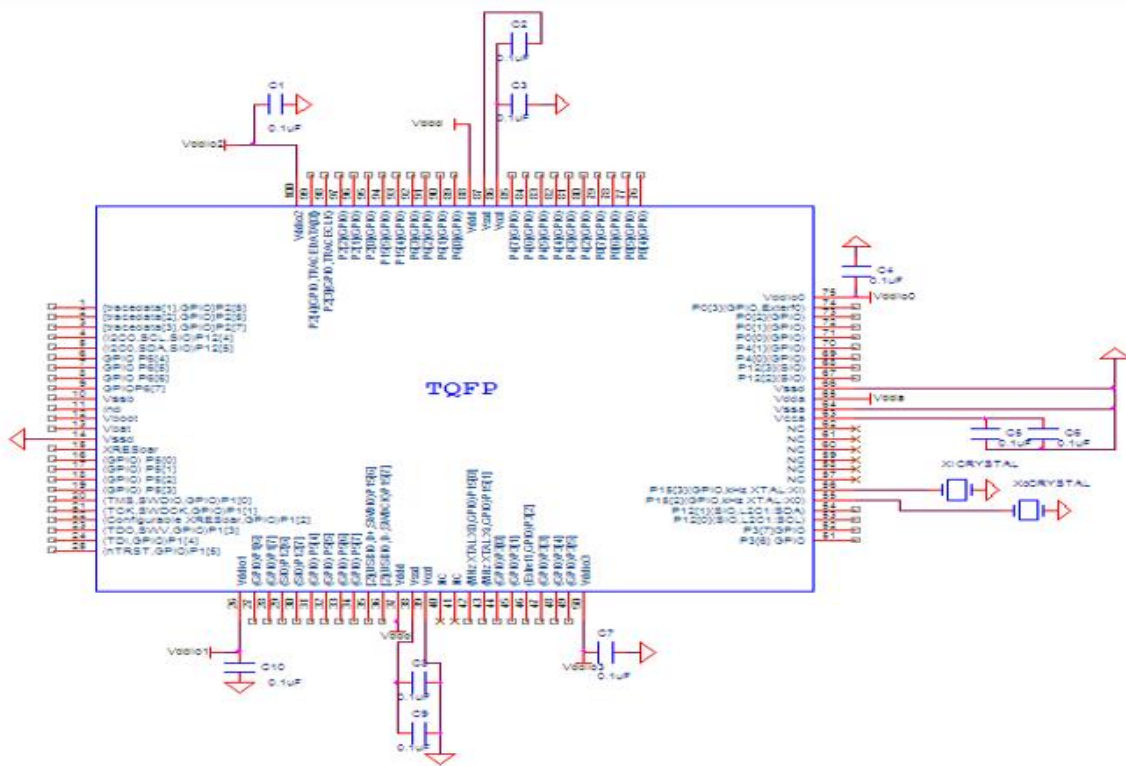

Fig 3.8: Schematic of PSoC

3.5 PHOTODETECTOR

Photodetectors commonly utilized for converting light into current and principle used by photodetectors is the photoelectric effect, which is the effect on a circuit due to light. In 1900, Max Planck discovered quanta which define that energy is radiated in small discrete units and also determined a universal constant of nature which is known as the Planck's constant. The discoveries of Planck's lead to a new form of physics known as quantum mechanics and the photoelectric effect $E = hv$ which is Planck constant multiplied by the frequency of radiation. The effect of light on a surface of the metal in a vacuum is known as photoelectric effect, then the result is that electrons being ejected from the surface explain the principle theory of light energy which allows

photodetectors to operate. These photodetectors may be use in conjunction with other optical devices to form security systems also used as safety devices in homes in the form of a smoke detector. (7)

SHEMATIC

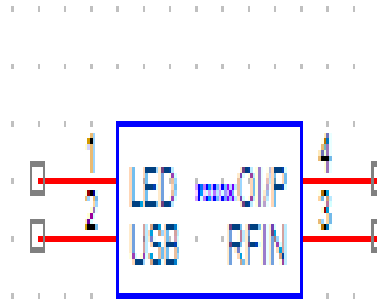

Fig 3.9: Schematic of photodetector

3.6 TRANSIMPEDANCE AMPLIFIER

The trans-impedance amplifier is a type of transducer that is used as a current to voltage converter and usually used in the operational amplifier. Here TIA is used to amplify the current output of photomultiplier tubes, photodetectors, accelerometers, and other types of sensors to a usable voltage. Sensors are used with the current to voltage converters which have the current response linear then voltage response. For photodiode, the trans-impedance amplifier provides low impedance and also isolates it from the voltage at the output of the op-amp. Transimpedance amplifier has a large valued feedback resistor R_f and the gain is set by using this resistor having value $-R_f$. There are many types of configurations of trans-impedance amplifiers suited to the particular application and one common factor is a requirement to convert a low-level current of a sensor to voltage. Transimpedance amplifiers of different configurations require different type sensors of that can provide a high gain, bandwidth, as well as current and voltage offsets, change. (9)

3.7 LNA

A low-noise amplifier (LNA) is a kind of electronic amplifier that amplifies a low-power signal without significantly degrading its signal-to-noise ratio. The amplifier increases the power of both the signal and the noise that present at its input. LNAs is one that is designed to minimize additional noise. Here designer reduces noise by considering trade-offs that include impedance matching, choosing the correct amplifier technology (low-noise components) and selecting low-noise biasing conditions. (10)

4. DEVICE DESIGN IMPACT ON PHOTODETECTOR

The desire for high-frequency direct and external modulation having links with high gain, low NF, and wide SFDR drives the necessity for photodetectors that respond efficiently and linearly to light that is modulated by high-frequency analog signals. In the case of an external modulation links, whose performance is generally better for larger values of optical power, the importance of responding linearly to modulated light that has a large average value was also stressed as an important desired quality of the detector.

The future availability of high-speed detectors with greater optical power-handling capacity will enable external modulation links to have increased gain and reduced NF. The optical power-handling capacity is a most important factor in determining the achievable SFDR because it goes hand in hand with the device's linearity. In most conventional analog links those that do not use a linearized modulator the modulator's or directly modulated laser's nonlinearity dominates that of the link and thereby sets the limit on the link SFDR. It has been shown, however, that in links with linearized modulators, the detector's nonlinearity can set the upper limit on the SFDR.

5. SCHEMATIC

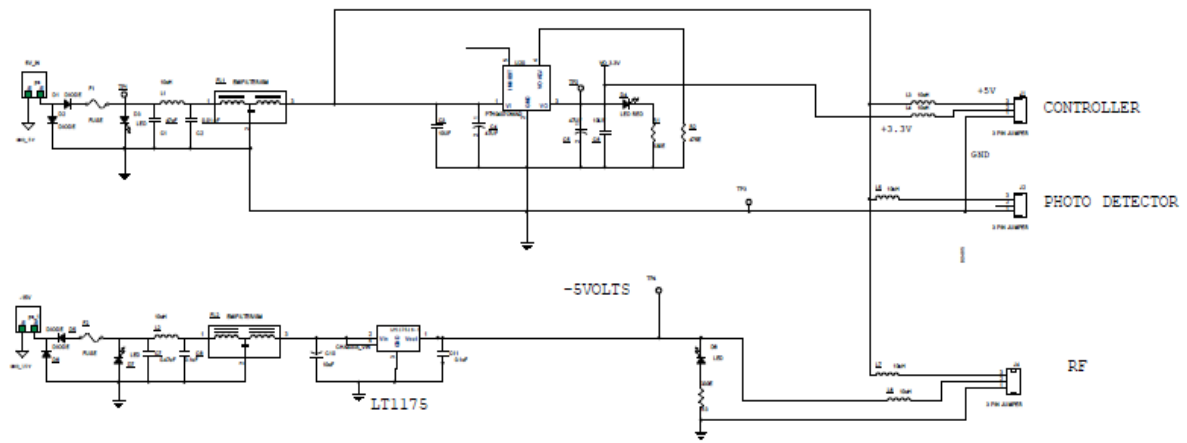

Fig 5.1: Schematic of power supply unit

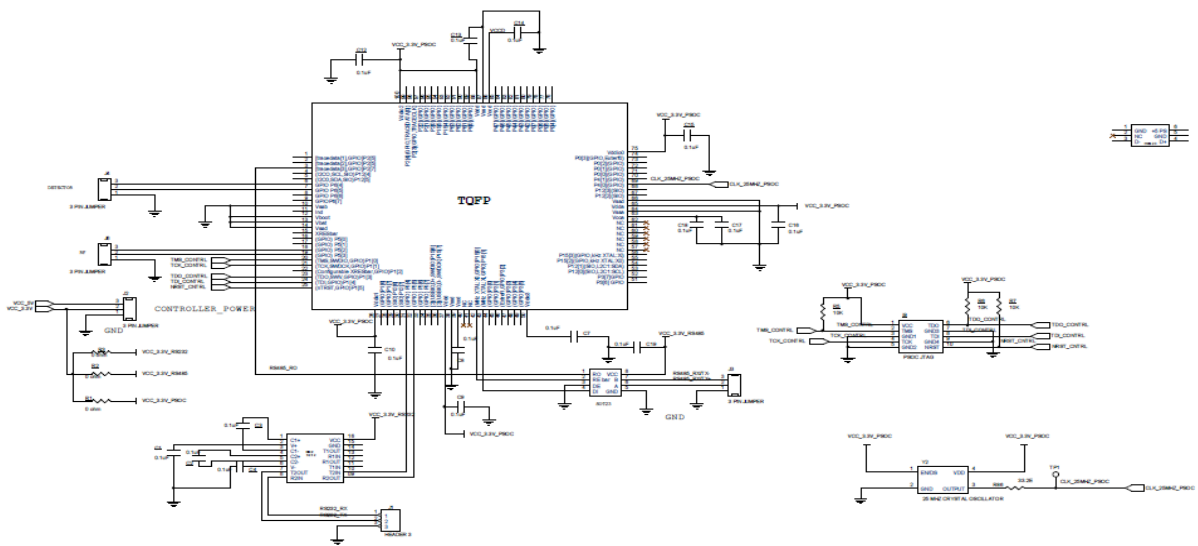

Fig 5.2: schematic of system

RESULTS

6.1 Simulation Output:

Simulation Setup:

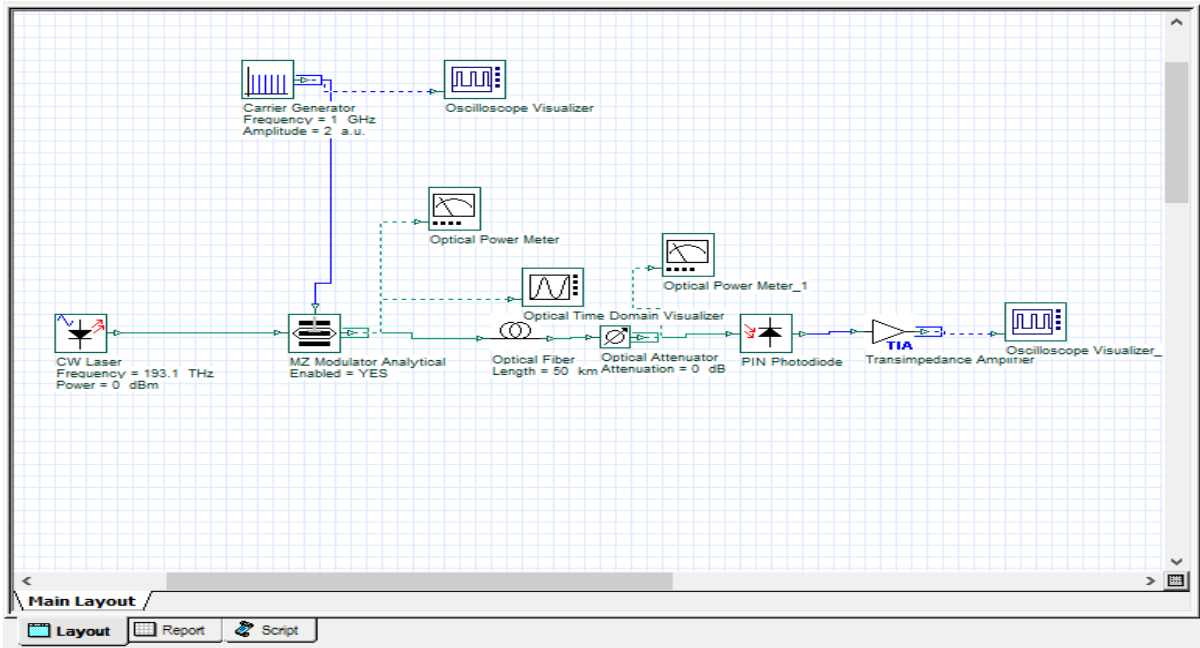

Fig 6.1: Simulation Setup

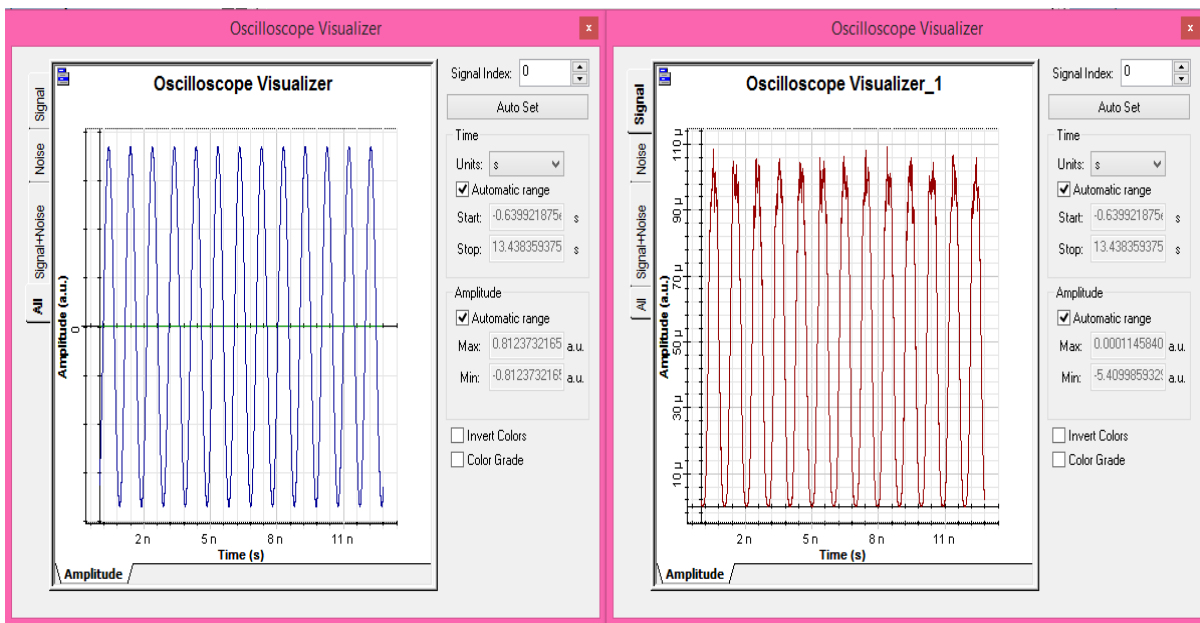

Fig 6.2 : Simulation Result

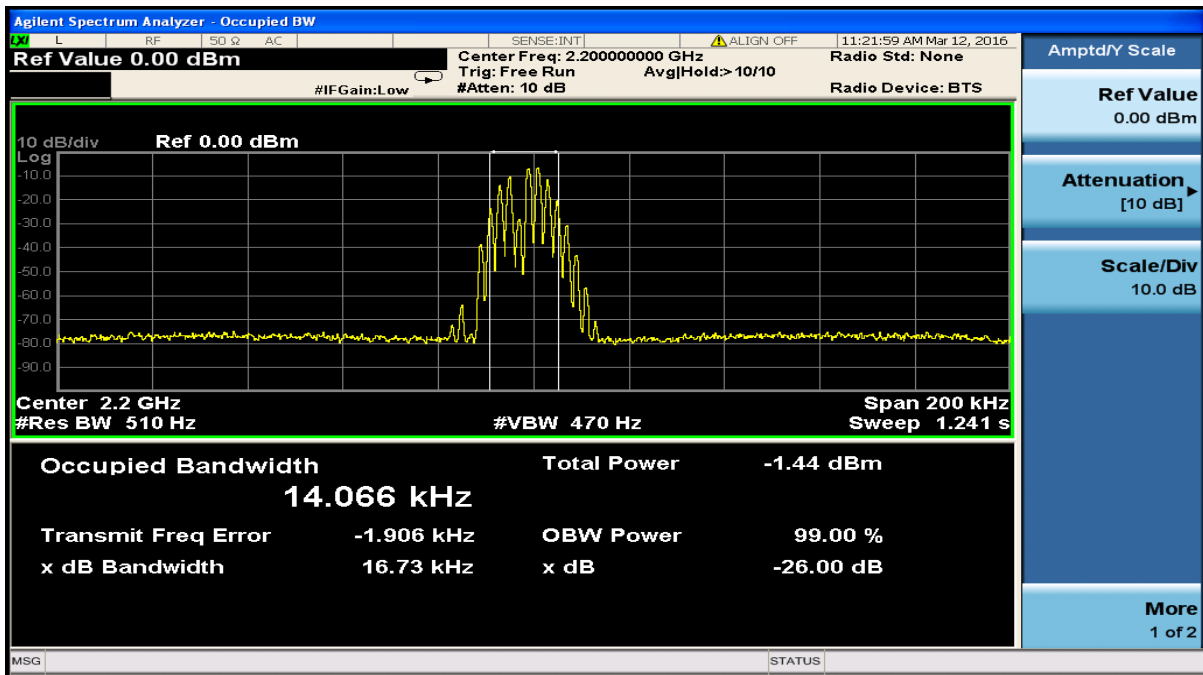

Fig 6.3: Output

CONCLUSION

In the proposed system, the optical signal is fed as input to the photo-detector and this photodetector converts optical signal to current signal. But in proposed system, there is no analog to digital conversion this system is completely an analog. The main pros of the RFoF technology are lesser attenuation loss, greater bandwidth, installation, and maintenance are easy. Hence from the test results conclusion is that Power level is decreased because of 15 dB attenuation provided by the RFoF system and also the RF over Fibre system is transparent to Amplitude Modulation.

REFERENCES

- [1] Dr. Mahendra Kumar “Advantages and Disadvantages of Radio Frequency” Volume: 5 | Issue: 10 | October 2015 | ISSN - 2249-555.
- [2] Pooja¹, Saroj², Manisha³ “Advantages and Limitation of Radio over Fibre System” IJCSMC, Vol. 4, Issue. 5, May 2015, pg. 506 – 511.
- [3] Mehedi Hasan “Photonic Integrated Circuit Architecture for Radio-over-Fibre Applications” May 2015.
- [4] F. Egan, William “Practical Rf system design” in *Proc. IEEE ICECS*, 2006, pp.1328–1331.
- [5] K. Esakki Muthu “Frequency16-tupled optical millimeter-wave generation using dual cascaded MZMs and 2.5 Gbps RoF transmission”, Volume 140, July 2017.
- [6] M. Niknamfar and M. Shadaram, “Two Sub-Carriers Multiplexed Millimeter Wave Generation Using Mach-Zehnder Modulators,” 2014 16th International Conference on Transparent Optical Networks (ICTON), July.2014, pp. 1-4, doi:10.1109/ICTON.2014.6876456.
- [7] N. A. Al-Shareefi, S. I. S. Hassan, F. Malek, R. Ngah, S. A. Aljunid, S. A. Abbas, and N. Anida, “A Study in OCS Millimeter-Wave Generation Using Two Parallel DD-MZMs,” 2013 IEEE 11th Malaysia International Conference on Communications, Nov. 2013, pp. 418-421, doi:10.1109/MICC.2013.6805865
- [8] Bertolotti, Mario (2015), *Masers and Lasers, Second Edition: A Historical Approach*, CRC Press, pp. 89–91, ISBN 9781482217803, retrieved March 15, 2016
- [9] S. Yu, W. Gu, A. Yang, T. Jiang, and C. Wang, “A Frequency Quadrupling optical mm-wave generation for hybrid fiber – wireless systems,” *IEEE Journal on selected areas in Communications-Part 2*, Vol. 31, No. 12, pp.797-803, 2013.
- [10] Cassidy, M. C.; Bruno, A.; Rubbert, S.; Irfan, M.; Kamhuber, J.; Schouten, R. N.; Akhmerov, A. R.; Kouwenhoven, L. P. (2 March 2017). “Demonstration of an ac Josephson junction laser”. *Science*. 355 (6328): 939–942. doi:10.1126/science.aah6640. Retrieved 4 March 2017.