



INTERNATIONAL JOURNAL OF ADVANCE RESEARCH, IDEAS AND INNOVATIONS IN TECHNOLOGY

ISSN: 2454-132X

Impact factor: 4.295

(Volume3, Issue3)

Available online at www.ijariit.com

Laplace Transforms and Its Applications

Manju Devi

S.D. (P.G.) College, Panipat

ghalyan.manju@gmail.com

Abstract: Laplace transform is a very powerful mathematical tool applied in various areas of engineering and science. With the increasing complexity of engineering problems, Laplace transforms help in solving complex problems with a very simple approach just like the applications of transfer functions to solve ordinary differential equations. This paper will discuss the applications of Laplace transforms in the area of physics followed by the application to electric circuit analysis. A more complex application of Load frequency control in the area of power systems engineering is also discussed.

Keywords: Algebraic Relations, Algorithm.

INTRODUCTION

Laplace transform is an integral transform method which is particularly useful in solving linear ordinary differential equations. It finds very wide applications in various areas of physics, electrical engineering, control engineering, optics, mathematics and signal processing. The Laplace transform can be interpreted as a transformation from the time domain where inputs and outputs are functions of time to the frequency domain where inputs and outputs are functions of complex angular frequency. In order for any function of time $f(t)$ to be Laplace transformable, it must satisfy the following Dirichlet conditions:

- $f(t)$ must be piecewise continuous which means that it must be single-valued but can have a finite number of finite isolated discontinuities for $t > 0$.
- $f(t)$ must be an exponential order which means that $f(t)$ must remain less than Se^{-ta_0} as t approaches ∞ where S is a positive constant and a_0 is a real positive number

If there is any function $f(t)$ that satisfies the Dirichlet conditions, then $F(s) = \int_0^{\infty} f(t)e^{-st} dt$

Written as $L(f(t))$ is called the Laplace transformation of $f(t)$. Here, s can be either a real variable or a complex quantity.

The integral $\int f(t)e^{-st} dt$ converges if $\int |f(t)e^{-st}| dt < \infty, s = \sigma + j\omega$

SOME IMPORTANT PROPERTIES OF LAPLACE TRANSFORMS

• Linearity

The Laplace transform of the linear sum of two Laplace transformable functions $f(t) + g(t)$ is given by

$$L(f(t) + g(t)) = F(s) + G(s)$$

• Differentiation

If the function $f(t)$ is piecewise continuous so that it has a continuous derivative $f^{n-1}(t)$ of order $n-1$ and a sectionally continuous derivative $f^n(t)$ in every finite interval $0 \leq t \leq T$, then let, $f(t)$ and all its derivatives through $f^{n-1}(t)$

be of exponential order e^{ct} as $t \rightarrow \infty$.

Then, the transform of $f^n(t)$ exists when $Re(s) > c$ and has the following form:

$$L f^n(t) = s^n F(s) - s^{n-1} f(0+) - s^{n-2} f'(0+) - \dots - s^{n-1} f^{(n-1)}(0+)$$

• Time delay

The substitution of $t - \lambda$ for the variable t in the transform $L f(t)$ corresponds to the multiplication of the function $F(s)$ by $e^{-\lambda s}$, that is

$$L(f(t - \lambda)) = e^{-s\lambda} F(s)$$

APPLICATIONS OF LAPLACE TRANSFORMS

This section describes the applications of Laplace transforms in the areas of science and engineering. At first, a simple application in the area of Physics and Electric Circuit theory is presented which will be followed by a more complex application to a power system which includes the description of Load Frequency Control (LFC) for transient stability studies.

Application in Physics

A very simple application of Laplace transform in the area of physics could be to find out the harmonic vibration of a beam which is supported at its two ends.

Let us consider a beam of length l and uniform cross section parallel to the yz plane so that the normal deflection $w(x,t)$ is measured downward if the axis of the beam is towards x axis. The basic equation defining this phenomenon is as given below:

$$EI d^4 w/dx^4 - m\omega^2 w = 0; \quad (1)$$

Where E is Young's modulus of elasticity; I is the moment of inertia of the cross-section with respect to the y axis; m is the mass per unit length; and ω is the angular frequency.

Now, rewriting the Eq(1) by setting $\alpha^4 = m\omega^2 w/EI$

we obtain,

$$d^4 w/dx^4 - \alpha^4 w = 0; \quad (2)$$

Now, applying the Laplace transform to Eq(2),

$$s^4 f(s) - s^3 F(+0) - s^2 F'(+0) - s F''(+0) - F'''(+0) - \alpha^4 f(s) = 0$$

The boundary conditions for this problem are:

$$F(+0) = 0; F(+l) = 0; F''(+0) = 0; F''(+l) = 0;$$

Hence, we obtain,

$$f(s) = (s^2 F'(+0) + F'''(+0))/s^4 - \alpha^4$$

The inverse Laplace transform gives,

$$\omega = \frac{F'(+0)}{2\alpha} \sinh \alpha x + \sin \alpha x + \frac{F'''(+0)}{2\alpha^3} \sinh \alpha x - \sin \alpha x$$

That is, $\omega = A_1 \sinh \alpha x + A_2 \sin \alpha x$.

When $x = l$; $A_1 \sinh \alpha l + A_2 \sin \alpha l = 0$; $A_1 \sinh \alpha l - A_2 \sin \alpha l = 0$;

These are satisfied if $A_1 = A_2 = 0$ i.e $\sinh \alpha l = \sin \alpha l = 0$.

This will give, $\alpha l = n \pi$, for integral values of n . Hence, $A_1 = 0$ and A_2 is undetermined and the resulting vibrations are :

$$w_n = A_n \sin \left(\frac{n\pi x}{l} \right), \text{ and the frequencies are}$$

$$\omega_n = \frac{\pi^2 n^2}{l^2} \sqrt{EI/m}$$

Here, if $n = 1$, it represents the fundamental vibration and if $n = 2$ the first harmonic and so on.

APPLICATION IN ELECTRIC CIRCUIT THEORY

The Laplace transform can be applied to solve the switching transient phenomenon in the series or parallel RL, RC or RLC circuits. A simple example of showing this application follows next.

Let us consider a series RLC circuit as shown in Fig 1. to which a d.c. Voltage V_0 is suddenly applied.

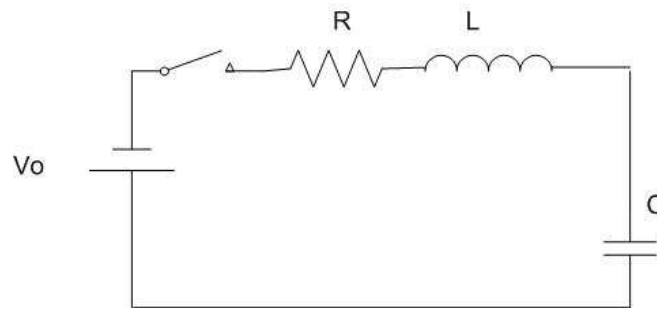

FIG. 1: Series RLC circuit

Now, applying Kirchoff's Voltage Law (KVL) to the circuit, we have,

$$Ri + Ldi/dt + 1/C \int idt = V_o \quad (3)$$

Differentiating both sides,

$$Ld^2 i/dt^2 + 1/Ci + Rdi/dt = 0;$$

$$\text{or, } d^2 i/dt^2 + (R/L)di/dt + (1/LC)i = 0 \quad (4)$$

Now, applying laplace transform to this equation, let us assume that the solution of this equation is $i(t) = Ke^{st}$ where K and s are constants which may be real, imaginary or complex

Now, from eqn (4),

$$LKs^2e^{st} + RKe^{st} + 1/CKe^{st} = 0 \text{ which on simplification gives,}$$

$$\text{or, } s^2 + (R/L)s + 1/LC = 0$$

$$\text{The roots of this equation would be } S_1, S_2 = R/2L \pm \sqrt{\frac{R^2}{4L^2} - 1/LC}$$

The general solution of the differential equation is thus, $i(t) = K_1 e^{s_1 t} + K_2 e^{s_2 t}$ where K_1 and K_2 are determined from the initial conditions.

Now, if we define $\alpha = \text{Damping Coefficient} = R/2L$ and Natural Frequency, $\omega_n = 1/\sqrt{LC}$ which is also known as undamped natural frequency or resonant frequency.

$$\text{Thus, roots are: } S_1, S_2 = -\alpha \pm \sqrt{\alpha^2 - \omega_n^2}$$

The final form of solution depends on whether

$$(R^2/4L^2) > 1/LC; (R^2/4L^2) = 1/LC \text{ and } (R^2/4L^2) < 1/LC$$

The three cases can be analysed based on the initial conditions of the circuit which are: overdamped case if $\alpha > \omega_n$ Critically damped case if $\alpha = \omega_n$ and under-damped case if $\alpha < \omega_n$.

Application in Power Systems Load Frequency Control

Power systems are comprised of generation, transmission and distribution systems. A generating system consists of a turbogenerator set in which a turbine drives the electrical generator and the generator serves the loads through transmission and distribution lines. It is required that the system voltage and frequency have to be maintained at some pre-specified standards eg. frequency have to be maintained at 50 or 60 Hz and voltage magnitude should be 0.95-1.05 per unit. In an interconnected power system, Load Frequency Control (LFC) and Automatic Voltage Regulator (AVR) equipment are installed for each generator. The controllers are set for a particular operating condition and take care of small changes in load demand to maintain the frequency and voltage within specified limits. Changes in real power are dependent on the rotor angle, δ and thus system frequency and the reactive power is dependent on the voltage magnitude that is, the generator excitation. In order to design the control system, the initial step is the modeling of generator, load, prime mover (turbine) and governor.

1. Generator Model

The modeling of a generator by applying the swing equation of a synchronous machine. When the small perturbation is applied to the swing equation, the equation modifies as follows:

$$(2H/\omega_s)(d^2\Delta\delta/dt^2) = \Delta P_m - \Delta P_e \quad (5)$$

This can be written for a small deviation in speed with speed expressed in per unit as

$$d\Delta\omega/dt = \frac{1}{2H} (\Delta P_m - \Delta P_e) \quad (6)$$

Now, applying Laplace transform to Eq(6), we obtain

$$\Delta\Omega(s) = 1/2Hs[\Delta P_m(s) - \Delta P_e(s)] \quad (7)$$

This relation can be shown in the block diagram in fig.

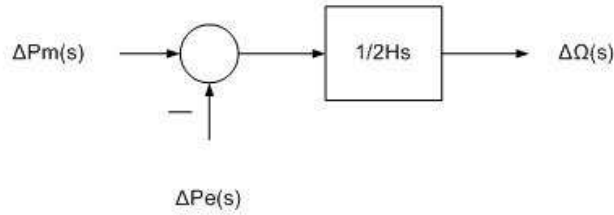

Fig.2: Generator block diagram

1. Load model

The loads in the power system comprised of different kinds of electrical devices. Some loads are frequency dependents such as motor loads and other loads like lighting and heating loads are independent of frequency. The frequency sensitivity of the loads depends on the speed-load characteristics of all the driven devices. The speed-load characteristic of a composite load is approximated by

$$\Delta P_e = \Delta P_L + D\Delta\omega \quad (8); \quad \text{where } \Delta P_L \text{ is the non frequency sensitive load change and } D\Delta\omega \text{ is the frequency sensitive load change. } D \text{ is expressed as a percentage change in load divided by percent change in frequency.}$$

The combined block diagram representation of generator and load is as shown in Fig

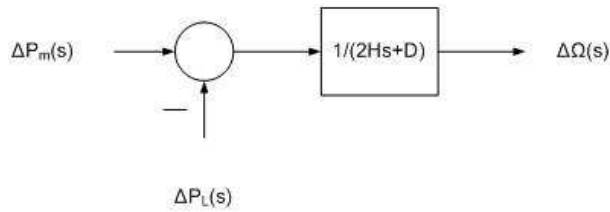

Fig.3: Generator and load block diagram

2. Prime mover model

Prime mover is the source of mechanical power which can be hydraulic turbines or steam turbines. The modeling of the turbine is related to the change in mechanical power output ΔP_m to the change in steam valve position ΔP_v . The simplest prime mover model for a steam turbine can be developed by a single time constant, τ_T and hence, the resulting transfer function is as follows:

$$G_T(s) = \Delta P_m(s)/\Delta P_v(s) = 1/1+\tau_T(s) \quad (9)$$

The block diagram of a simple turbine is shown in Fig

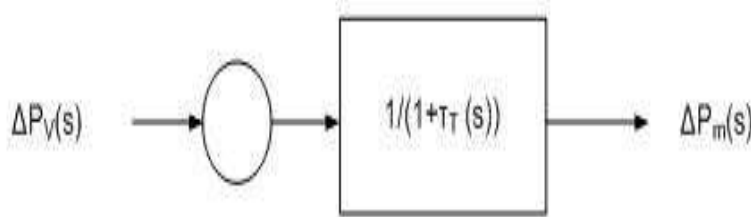

Fig. 4: Prime mover block diagram

3. Governor Model

During the cases when the generator load is suddenly increased, the electrical power exceeds the mechanical power input and this deficiency of power is supplied by the kinetic energy stored in the rotating system. Due to this reduction in kinetic energy, the turbine speed and hence, the generator frequency gets reduced. The turbine governor senses this reduction in speed and acts to adjust the turbine input valve to change the mechanical power output to bring the speed to a new steady state.

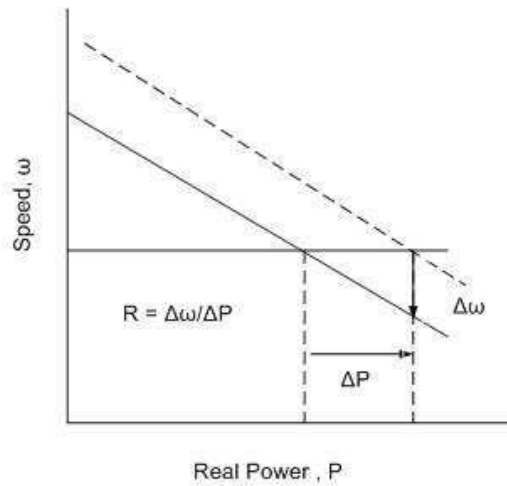

FIG.5: Governor speed characteristics

The governors are designed to permit the speed to drop as the load is increased. The steady-state characteristics of a governor are as shown in Fig.5. The slope of this curve represents the speed regulation R. The speed governor mechanism acts as a comparator whose output ΔP_g is the difference between the reference set power ΔP_{ref} and the power $1/R\Delta\omega$ given by the governor speed characteristic shown in Fig.5 which can be expressed as follows: $\Delta P_g = \Delta P_{ref} - 1/R\Delta\omega$ (10)

Again, applying Laplace transform, in s-domain,

$$\Delta P_g(s) = \Delta P_{ref}(s) - 1/R\Delta\omega(s) \quad (11)$$

The command ΔP_g is transformed to the steam valve position, ΔP_v , assuming the linear relationship and considering a time constant, τ_g so that we have following s-domain relationship:

$$\Delta P_v(s) = 1/(1+\tau_g(s)) \Delta P_g(s) \quad (12)$$

The combination of eqn (11) and (12) can be represented by a block diagram of a governor model as shown in Fig

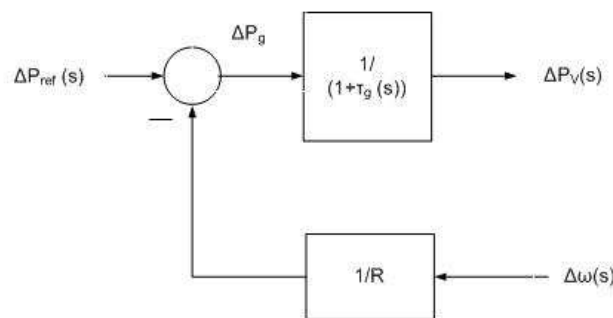

FIG.6: Steam turbine speed governing system block diagram

Now, combining the block diagrams of generator, load, turbine and governor systems as shown in Fig 2, 4 and 6, we obtain the overall block diagram of the load frequency control of an isolated power system as shown in Fig 7.

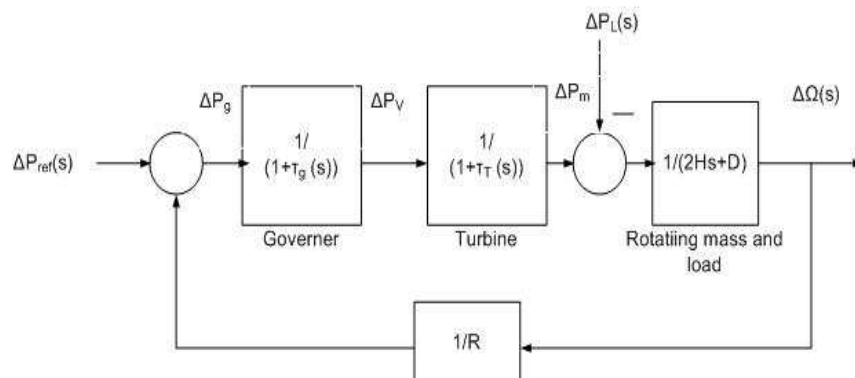

Fig 7: Block diagram of load frequency control of isolated power system

From Fig 7, the closed loop transfer function relating the load change ΔP_L to the frequency deviation $\Delta\Omega$ is given by:

$$\frac{\Delta\Omega(s)}{-\Delta P_L(s)} = \frac{(1+\tau_g(s))(1+\tau_T(s))}{(2H_s+D)(1+\tau_g(s))(1+\tau_T(s))+1/R}$$

That is: $\Delta\Omega(s) = -\Delta P_L(s)T(s)$

The load change is a step input i.e. $\Delta P_L(s) = \Delta P_L/s$

Thus again applying the final value theorem we, obtain the steady state value of $\Delta\omega$ as $\omega_{ss} = \lim_{s \rightarrow 0} s\Delta\Omega(s) = (-\Delta P_L)1/D + 1/R$

A simple simulation is carried out in MATLAB Simulink with the load frequency block diagram shown in Fig 7. The values of the different parameters are: turbine time constant $\tau_T = 0.5$ sec; governor time constant $\tau_g = 0.2$ sec; Generator inertia constant, $H = 5$ sec; speed regulation, $1/R = 0.05$ pu and $\Delta P_L = 0.2$ pu. The plot in Fig 8 shows that there is a steady error in frequency of around -0.0096 pu. with this load frequency control mechanism. This application can be extended to a more complex Automatic Generation Control (AGC) in which the system frequency is automatically adjusted to the nominal value as the system load change continuously with zero steady state frequency error.

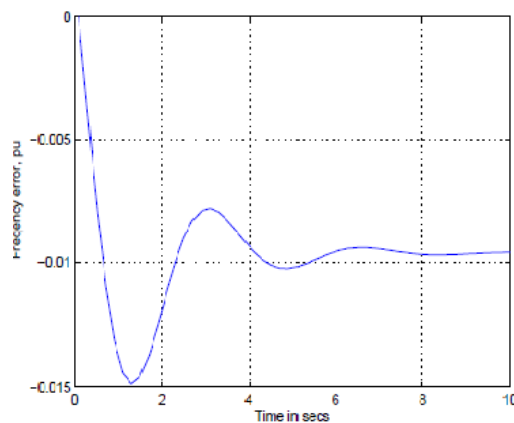

FIG. 8: Frequency deviation step response

Thus Laplace transform can be applied in finding out the steady state frequency deviation of isolated power systems properly modeled with s-domain equations.

CONCLUSION

The paper presented the application of Laplace transform in different areas of physics and electrical power engineering. Besides these, Laplace transform is a very effective mathematical tool to simplify very complex problems in the area of stability and control. With the ease of application of Laplace transforms in a myriad of scientific applications, many research software have made it possible to simulate the Laplace transformable equations directly which has made a good advancement in the research field.

REFERENCES

- [1] A. D. Poularikas, *The Transforms and Applications Handbook* (McGraw Hill, 2000), 2nd ed.
- [2] M.J.Roberts, *Fundamentals of Signals and Systems* (Mc-Graw Hill, 2006), 2nd ed.
- [3] K. Riess, *American Journal of Physics*.
- [4] M. N. S. Charles K. Alexander, *Fundamentals of Electric Circuits* (McGraw Hill, 2006), 2nd ed.
- [5] H. Saadat, *Power System Analysis* (McGraw Hill, 2002), 2nd ed.