



# INTERNATIONAL JOURNAL OF ADVANCE RESEARCH, IDEAS AND INNOVATIONS IN TECHNOLOGY

ISSN: 2454-132X

Impact factor: 4.295

(Volume3, Issue2)

## Web Hosting and Live Streaming Using Raspberry-Pi for Home Automation

**Anuja A. Borkar**  
Computer dept. Viva  
College

[Namita\\_ms@yahoo.com](mailto:Namita_ms@yahoo.com)

**Krutika D. Sargar**  
Computer dept. Viva  
College

[Krutikasagar123@gmail.com](mailto:Krutikasagar123@gmail.com)

**Siddhi U. Jadhav**  
Computer dept. Viva  
College

[Sidjadhav8793@gmail.com](mailto:Sidjadhav8793@gmail.com)

**Shraddha J. Satpute**  
Computer dept. Viva  
College

[Shraddhasatpute14121994@gmail.com](mailto:Shraddhasatpute14121994@gmail.com)

**Ruchika R. Karande**  
Computer dept. Viva College

[Ruchikakarande14@gmail.com](mailto:Ruchikakarande14@gmail.com)

---

**Abstract:** In this busy and comfortable lifestyle of peoples, communication technology has evolved in such a way that any information will be accessed from anywhere, at any time, by any one. In today's communication technology, communication is not only constrained between two computers, but it is a complete network called the internet. With advanced internet technology today not only we can access the information from anyplace, at any time, by any person, but we can also control and monitor various devices from anyplace, at any time, by any authenticated person, this technology is called Internet of Things (IoT). This report represents the application of IoT for Smart Home Automation system which includes a Raspberry Pi as a processing unit for data which is extracted from various sub-systems like, Temperature sensing system, Automatic light system, Cooling system, and Gas detection system, Water level sensing system, Motion detection system and Lights on and off system. All these systems are monitored and controlled remotely by a web page.

**Keywords:** Raspberry-pi, IOT, Arduino, GUI.

---

### I. INTRODUCTION

In the previous prototypes, the controlling of home appliances were done with the help of simple switches mounted to a board on a wall. There were many emerging trends in the field of Home Automation and security. Today a worldwide multitude of Internet connections are devices used directly by humans like computers and mobile handsets, in other words, we can say it's a human to human communication. In not a distance future, it's possible that we can have not only human-human communication but also device-device communication which is called "Internet of Things" where Things refers to various electronic devices.

The term 'Internet of Things' was firstly coined by Kevin Ashton in a presentation in 1998, he described an IoT as a system where the digital world is connected to the physical world forming a global network [1]. With IoT not only we can access the information from anyplace, at any time, by any person, but we can also control and monitor various devices from anyplace, at any time, on any network, by any authenticated person, this technology is called Internet of Things (IOT).

The concept of IoT aims in making the Internet more ubiquitous and immersive. Thus accelerating the internet to make it enable by any authorized person for easy access and to have an interaction with enormous variety of devices for instance, home gadgets, spying cameras, monitoring sensors, actuators, automobiles, displays, and so on, the It will nurture the development of a number of applications that make use of the virtually enormous amount and variety of data generated by Things to provide new benefits to citizens, industry, and government sectors.

In the proposed solution, one can control the home appliance from network around and can see what's going on in a room from anywhere around the globe using Internet of Things Framework. A simple Pi Cam is interfaced to the processor for live streaming to see what's happening through the Internet.

### II. LITERATURE SURVEY

Now a days many more digital appliances are populated in our homes, it is necessary that all of them have to be networked in such fashion that they can be monitored and controlled from anywhere, at any time, by an authenticated person, this is called Smart Home Automation System (SHAS). SHAS provides comfort, security, and energy efficiency of an in-home environment equipment. Home automation technology can make home environment more convenient. If the user is at work or on vacation, a HAS is built in such a way that it should notify the user about the present condition of an in-home environment and also should take required precaution measures in an emergency. The development of SHAS has existed for many years, the term "smart house" was coined by American

Association of House builders in 1984 [4]. It all started with a group of students who did a simple experiment on alarm clock whose two hands were connected to the two electric wires which in turn created a closed circuit of battery and a bulb at a particular time of the clock when two hands of clock meet. Thus making the bulb glow to glowing when the user wishes. Today we see a significant increase in home automation technology due to higher affordability and advancement in Smartphones which allows vast connectivity.

This paper proposes an Arduino based Home Automation System, in this system various sensors are used to sense the data and this data is updated on a webpage through the Arduino processor and even user can control the device through internet. The drawback of this system are Arduino does not have Ethernet shield and compatibility of the operating system for programming. To overcome all these drawbacks we have used a Raspberry Pi as a core processing unit so as to satisfy the need of IoT.

### III. PROPOSED SYSTEM

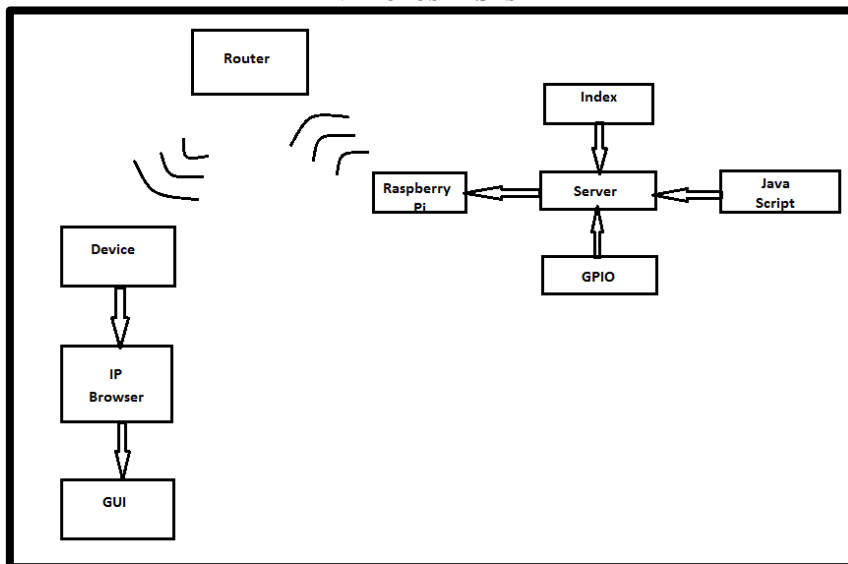

Every user who is experienced in the existing system may think of a system that may add more flexibility and run with some common applications such as android. The proposed system is designed in such a way to avoid the limitations of the existing system. The proposed system supports more flexibility, comfort ability, and security. The proposed home automation system is working with very popular android phones. It is having mainly three components; the android enabled user device, a wifi router having a good scalable range, and a raspberry pi board. Here the users have provision to control the home appliances through the android enabled device. This will improve the system popularity since there is no need for a wired connection, the internet etc. The instructions from the user will be transmitted through the wifi network. The raspberry pi board is configured according to the home system and it will enable the relay circuit as per user request. The relay circuit can control the home appliances also. We can add appliances to the system also can add additional security features. The main objectives of the proposed system are to design and to implement a cheap and open source home automation system that is capable of controlling and automating most of the house appliances through an android device. Advantages of proposed System

- The new system must provide the following features
- It allows more flexibility through the android device.
  - It allows a good range of scalability.
  - It provides security and authentication.
  - Additional vendors can be easily added.

Flow Chart of Proposed System.

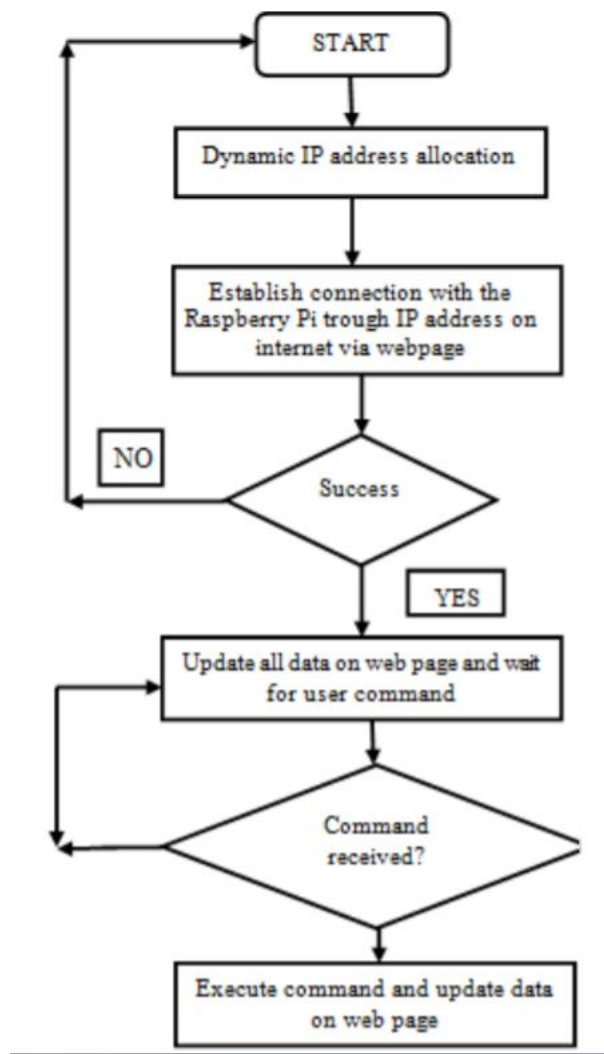

IV. SYSTEM ARCHITECTURE

The system architecture of this proposed system is explained with the block diagram. Each block represents the way we are navigating the proposed project. It contains mainly seven blocks and master of all blocks is Raspberry Pi Processor. We have used Raspberry Pi B+ processor. We can use any flavor of Raspberry pi

For controlling the home appliance, I've interfaced Relay board which is connected to Raspberry pi and for live streaming I've interface devices to the Raspberry Pi. For home appliance control have designed framework using Internet of Things and to connect this Internet. I have connected WIFI dongle to the Raspberry Pi. Raspberry Pi works at 5V 1A for that I have used Power Bank.

Above we have discussed what we have used in hardware now let's look into the software, the processor Raspberry Pi is completely Linux based operating system. It is having its own Linux Operating System and the programming language is Python. Every motion of the system has done in Python itself. We have explained each block in depth in the next session.

Home appliance network (home automation) is required to be without new wiring and to be very easy installation. Field of home appliance network is still young, many initiatives and standardization efforts have already been made. The new kind of system brought android and raspberry-pi into home automation implementation. The proposed system architectures generally incorporate a raspberry-pi computer for the purposes of network management and provision of remote access .raspberry-pi can be configured according to our home system.

The user will communicate to raspberry-pi through a wifi network. The system is flexible and scalable, allowing additional home appliances designed by multiple vendors, to be securely and safely added to the home network with the minimum amount of effort. The wifi network should be having adequate strength also. We can use a wifi-modem for stepping a wifi. The user can have a nice android interface for using the system. The serial data coming from wifi unit is connected to the raspberry-pi circuit. The core of the home automation system consists of raspberry-pi board. It can be viewed as a mini computer capable of doing many functions. The raspberry-pi board is configured for each home appliances .so according to user intervention the matched out will make high

and the corresponding relay will switch on and device start function. The system is scalable and allows multi-vendor appliances to be added with no major changes to its core. This project mainly consists of three modules as follows.

- 1) User Interface
- 2) Wifi Router Configuration
- 3) Raspberry Pi
- 4) Relay circuit
- 5) Appliances.

#### 4.1 Description of Modules

##### User Interface

The user interface is everything that the user can see and interact with. In this module, the android enabled phone makes control of the home automation system. Android provides a variety of pre-build UI components such as structured layout objects and UI controls that allow you to build the graphical user interface for your app. Android also provides other UI modules for special interfaces such as dialogs, notifications, and menus. The interface should allow the user to view device status and to control device.

##### Wifi Router Configuration

The wifi unit provides the medium for communication .it can be also configured to make security services. The wifi should be configured with a certain address and user commands will be directing through wifi unit. You may use Sudo nano /etc/network/interfaces for configuring wifi with raspberry-pi.

##### Raspberry Pi

The Raspberry Pi is a low-cost single-board computer which is controlled by a modified version of Debian Linux optimized for the ARM architecture. The core of the home automation system is this minicomputer. Here we are using modelB, 1GHz ARM processor with 1024 MB RAM. The setting up of raspi consists of selecting raspbian OS from noobs package. The noobs package consists of raspbian, arclinux, pidora, open ELEC, risc OS operating system. After the os selection we need to configure raspberry-pi using Raspi-config command. We can enter into raspi desktop using startx command.

To interface raspberry-pi with the external world we can use WebIOPi. WebIOPi is a web application which allows to control Raspberry Pi's GPIO. It Support REST API over HTTP and CoAP .it can also handle more than 30 devices including ADC, DAC, sensors. The webIoPi interface allows better control of raspi. The webIoPi Extensible and highly customizable and makes raspi control more efficient.

##### Relay Circuit

A relay is an electrically operated switch. Relays are used where it is necessary to control a circuit by a low-power signal (with complete electrical isolation between control and controlled circuits), or where several circuits must be controlled by one signal.in our system, the output from rapi is directly given to relay circuit. According to the out of raspi, corresponding relay will turn on and makes its device working. We are using a NPN transistor in relay and it works based on concept of emf. The relay can be selected according to our application purpose.

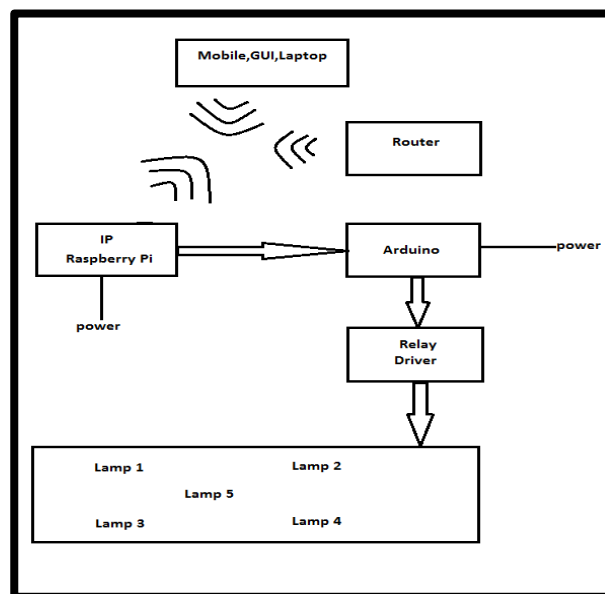

#### CONCLUSION

Smart home automation system which is the most commercial application of Internet of Things has experimentally verified satisfactorily we have connected the small appliance to it and we were able to control them remotely through the internet using the webpage and also can monitor the area surrounding through the camera installed in that area. This will help the users of any age to control and monitor their home from anywhere in the world at any time.

**REFERENCES**

- [1] K. Ashton, "That 'Internet of Things' Thing", RFID Journal, 22 June 2009.
- [2] Rajeev Piyare, "Internet of Things: Ubiquitous Home Control and Monitoring System using Android based Smart Phone", International Journal of Internet of Things 2013, 2(1): 5-11
- [3] Dr.Ovidiu vermesan and Dr.Peter fries, "Internet of things-from research and innovation to market development", River publication, 2014.
- [4] Suraj Bhatia, Jatin Bajaj, M. Mani Roja "Technology, Systems and Implementation of a Smart Home Automation System: A Review" IJCTA Sept-Oct 2014, ISSN:2229-6093.
- [5] Dhawan S. Thakur and Aditi Sharma, "Voice Recognition Wireless Home Automation System Based On Zigbee", in IOSR Journal of Electronics and Communication Engineering (IOSR-JECE), Volume 6, Issue 1, May. - Jun. 2013
- [6] Akanksha Singh, Arijit Pal, Bijay Rai, "GSM Based Home Automation, Safety and Security System Using Android Mobile Phone" in International Journal of Engineering Research & Technology (IJERT), Vol. 4 Issue 05, May-2015.
- [7] A. Bonaccorsi, "On the Relationship between Firm Size and Export Intensity," Journal of International Business Studies, XXIII (4), pp. 605-635, 1992. (journal style)
- [8] Dr.Ovidiu vermesan and Dr.Peter fries, "Internet of things-from research and innovation to market development", River publication, 2014.
- [9] Dongyu wang, Dixon lo, Janak bhimani and Kazunori sugiura, "Anycontrol-IOT based appliances monitoring and controlling", IEEE 39th Annual International Computers, Software & Applications Conference, 2015.
- [10] Security System Using Android Mobile Phone" in International Journal of Engineering Research & Technology (IJERT), Vol. 4 Issue 05, May-2015.