

MODELLING SIMULATION AND ANALYSIS OF GRID CONNECTED WIND GENERATOR

Sandhya Thakur¹, Ullas Kumar Agrawal², Tomeshvar Dhivar³, Dr. Mithilesh Singh⁴

¹Assistant Professor, EEE Dept (KITE)

²Assistant Professor, EEE Dept (KITE)

³Assistant Professor, EEE Dept (KITE)

⁴Assistant Professor, EEE Dept (KITE)

E-mail:- sandhya_thakur04 @rediffmail.com, ullasagrawal01@yahoo.com, tomeshdurg@gmail.com, Mithil_singh@rediffmail.com

ABSTRACT

Wind generators can have a significant impact on the power flow, voltage profile and the power quality for customers and electricity suppliers. This requires a suitable tool to analyze the influence of wind generators on the distribution system. This paper presents a method to find the steady-state voltage stability region for each bus of a distribution power system, considering the presence of wind power generation. The maximum permissible load of each bus is calculated, so that it can operate with the voltage within the limits allowed by the power system utilities.

Keywords- Wind generator; Voltage stability; power generation; steady-state.

1.Introduction

Recently wind power generation has been experiencing a rapid development in a global scale. The size of wind turbines and wind farms are increasing quickly; a large amount of wind power is integrated into the power system. As the wind power penetration into the grid increases quickly, the influence of wind turbines on the power quality and voltage stability is becoming more and more important. It is well known that a huge penetration of wind energy in a power system may cause important problems due to the random nature of the wind and the characteristics of the wind generators. In large wind farms connected to the transmission network (110 kV – 220 kV) the main technical constraint to take into account is the power system transient stability that could be lost when, for example, a voltage dip causes the switch off of a large number of wind generators. In the case of smaller installations connected to weak electric grids such as medium voltage distribution networks, power quality problems may become a serious concern because of the proximity of the generators to the loads. The existence of voltage dips is one of the main disturbances related to power quality in distribution networks. In developed countries, it is known that from 75% up to 95% of the industrial sector claims to the electric distribution companies are related to problems originated by this disturbance type. These problems arise from the fact that many electrical loads are not designed to maintain their normal use behavior during a voltage dip. The aim of this paper is to conduct a voltage stability analysis using an iterative power system simulation package, to evaluate the impact of strategically placed wind generators on distribution systems with respect to the critical voltage variations and collapse margins. This paper concludes with the discussion of wind generators excellent options for voltage stability.

2.Induction machines

Induction machines are used extensively in the power system as induction motors but are not widely used as generators. Despite their simplicity in construction, they are not preferred as much as synchronous generators. This is mainly due to the defined relationship between the export of P and absorption of Q. However, induction generators have the benefits of providing large damping torque in the prime mover, which makes it suitable for the application in fixed speed wind

turbines. The fixed speed wind turbine uses a squirrel cage induction generator that is coupled to the power system through a connecting transformer as shown in Figure 1. Due to different operating speeds of the wind turbine rotor and generator, a gearbox is used to match these speeds. The generator slip slightly varies with the amount of generated power and is therefore not entirely constant.

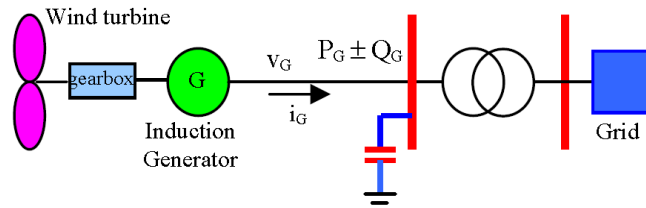

Figure 1. Modelling wind turbine connected grid.

However, because these speed variations are in the order of 1 per cent this wind turbine is normally referred to as constant speed. Nowadays, this type of wind turbine is nearly always combined with stall control of the aerodynamic power, although pitch-controlled constant speed wind turbine types have been built in the past. Induction machines consume reactive power and consequently, it is present practice to provide power factor correction capacitors at each wind turbine. These are typically rated at around 30 per cent of the wind farm capacity. As the stator voltage of most wind turbine electrical generators is 690V, the connecting transformer of the wind turbine is essential for connection to the distribution network and should be considered when modeling the electrical interaction with the power system [3].

3.Impacts of WGs.

Connecting a generation scheme to a distribution network will affect the operation and performance of the network depending on the scheme and rating of the generator itself. The impacts are (i) Power Flows, (ii) Voltage stability, (iii) Fault Analysis, and (iv) Impact of WTs on the Networks. Let us discuss each of them in detail.

A. Voltage Stability

A system experiences a state of voltage instability when there is a progressive or uncontrollable drop in voltage magnitude after a disturbance, increase in load demand or change in operating condition. The main factor, which causes these unacceptable voltage profiles, is the inability of the distribution system to meet the demand for reactive power. Under normal operating conditions, the bus voltage magnitude (V) increases as Q injected at the same bus is increased. However, when V of any one of the system's buses decreases with the increase in Q for that same bus, the system is said to be unstable. Although the voltage instability is a localized problem, its impact on the system can be wide spread as it depends on the relationship between transmitted P, injected Q and receiving end V. These relationships play an important role in the stability analysis and can be displayed graphically [1].

B. PV Curves

When considering voltage stability, the relationship between transmitted P and receiving end V is of interest. The voltage stability analysis process involves the transfer of P from one region of a system to another, and monitoring the effects to the system voltages. This type of analysis is commonly referred to as a PV study.

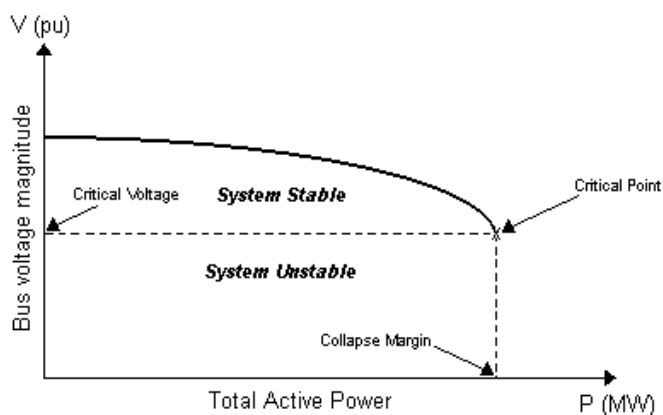

Figure 2. P-V Characteristics.

The Figure 2 shows a typical PV curve. It represents the variation in voltage at a particular bus as a function of the total active power supplied to loads or sinking areas. It can be seen that at the “knee” of the PV curve, the voltage drops rapidly when there is an increase in the load demand. Load flow solutions do not converge beyond this point, which indicates that the system has become unstable. This point is called the Critical point. Hence, the curve can be used to determine the system’s critical operating voltage and collapse margin. Generally, operating points above the critical point signifies a stable system. If the operating points are below the critical point, the system is diagnosed to be in an unstable condition [5].

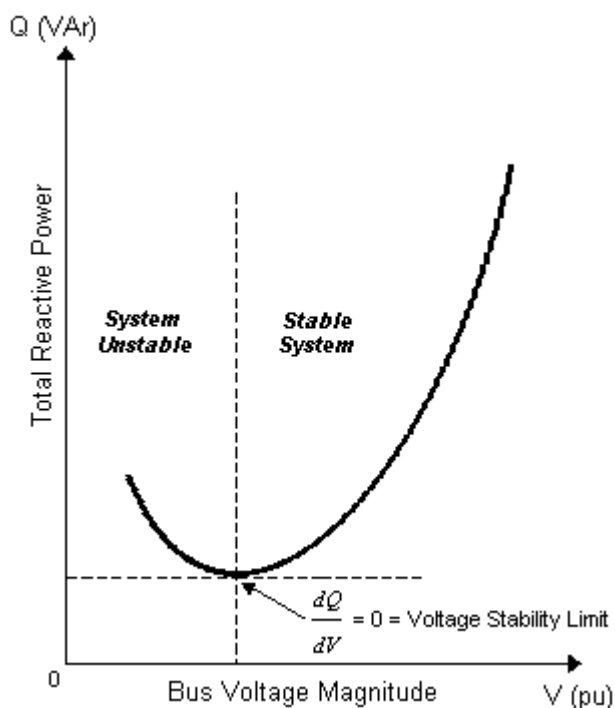

Figure 3. Q-V Characteristics.

C. QV Curves

Voltage stability depends on how the variations in Q and P affect the voltages at the load buses. The influence of reactive power characteristics of devices at the receiving end is more apparent in a QV relationship. It shows the sensitivity and variation of bus voltages with respect to reactive power injections or absorptions. Figure 3 shows a typical QV curve, which is usually generated by a series of load-flow solutions. Figure 3 shows a voltage stability limit at the point where the derivative dQ/dV is zero. This point also defines the minimum reactive power requirement for a stable operation. An increase in Q will result an increase in voltage during normal operating conditions. Hence, if the operating point is on the right side of the curve, the system is said to be stable. Conversely, operating points in the left side of the graph are deemed to be unstable [4,5].

D. PQ curves.

The maximum permissible loading of a system, within the voltage stability limit, is usually determined from the well-known P-V curve or Q-V curve. The P-V curve is plotted for a constant power factor and the Q-V curve is plotted for a constant power. A series of computer simulations is required to generate a family of these curves [6]. There are other methods to find the voltage stability limit of a system, such as multiple load flow solutions, singularity criterion of the Jacobian matrix [7]. It is an established fact that the voltage collapse occurs when the system load increases beyond a certain limit. If the limiting values of P and Q are known, the voltage stability margin for a given operating point can directly be determined. This requires the plotting of voltage stability boundary of the system in P-Q plane, however, using the limiting values of P and Q. To the best knowledge of the author, no such work has been reported so far that can determine the voltage stability margin using the P-Q curve.

The limiting or critical values of P and Q at the voltage collapse point are first determined and then used to plot the voltage stability boundary in P-Q plane. Unlike the conventional P-V or Q-V curves, no fixed value of power or power factor is used in generating the stability boundary [8]. Using the above curve, the voltage stability margin in terms of P, Q, or S (for a given power factor) can easily be determined when the initial operating point is known. Consider the equivalent π model of a distribution line connected between buses i and j as shown in Fig.4.

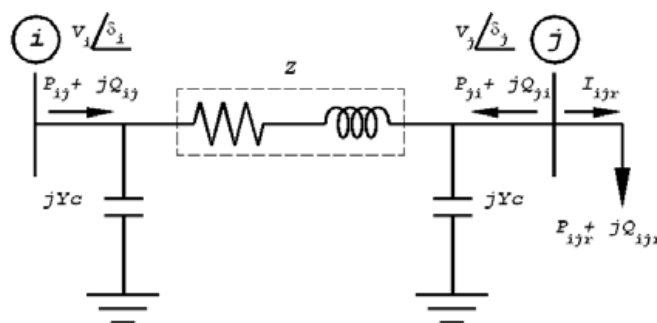

Figure 4. The π model distribution line connected between bus i and bus j.

We can formulate the relationship between injected current and voltage at any buses based on generalized ABCD parameters as follows:

$$V_i \angle \delta_i = AV_i \angle \delta_i + BI_j \quad (1)$$

where $A = 1 + ZYc$ and $B = Z$. The complex form of A and B can be expressed as shown in eq. (2).

$$A = a_1 + ja_2 \text{ and } B = b_1 + jb_2 \quad (2)$$

The receiving end current, I_{ijr} , can be expressed:

$$I_{ijr} = \frac{(P_{ijr} - jQ_{ijr})}{V_i \angle -\delta_i} \quad (3)$$

Substitute A and B from (2) and I_{ijr} from (3) into (1) resulting in (4).

$$V_i \angle \delta_i = (a_1 + ja_2)V_j \angle \delta_i + \frac{(b_1 + jb_2)(P_{ijr} + jQ_{ijr})}{V_j \angle \delta_j} \quad (4)$$

Or

$$aV_j^4 + aV_j^2 + c = 0 \quad (5)$$

Where

$$\begin{aligned} a &= a_1^2 + a_2^2; \\ b &= c_2 P_{ijr} + c_3 Q_{ijr} - V_i^2; \\ c &= c_4 (P_{ijr}^2 + Q_{ijr}^2) \\ c_1 &= a_1^2 + a_2^2; \\ c_2 &= 2(a_1 b_1 + a_2 b_2); \\ c_3 &= 2(a_1 b_2 + a_2 b_1); \\ c_4 &= b_1^2 + b_2^2; \end{aligned}$$

The solution of eq. (5) is the square of the receiving end voltage. Thus the receiving end voltage can be calculated from eq. (6).

$$V_j = \sqrt{\frac{-b \pm \sqrt{b^2 - 4ac}}{2a}} \quad (6)$$

There are two solutions for eq. (6), the lower solution lies on the lower part of the P-V curve and is unstable [4]. Thus, the available solution is a stable one on the upper half, which can be expressed as in eq. (7).

$$V_j = \sqrt{\frac{-b - \sqrt{b^2 - 4ac}}{2a}} \quad (7)$$

The point where the two trajectories, i.e. stable and unstable lines, are joined is the nose or bifurcation point. In addition, this is the point where the maximum power can be transferred, which is the condition $b^2 - 4ac$. Substitute coefficients of the quadratic equation from eq. (4) into eq. (7) and rearrange, we obtain (8).

$$\begin{aligned} &(c_2^2 - 4c_1c_4)P_{ijr}^2 + (c_3^2 - 4c_1c_4)Q_{ijr}^2 \\ &- 2c_2V_i^2P_{ijr} + 2c_3V_i^2Q_{ijr} + 2c_2c_3Q_{ijr} + V_i^4 \end{aligned} \quad (8)$$

The relationship between P_{ijr} and Q_{ijr} of eq. (8) is a locus of the collapsing point on the P-Q plane which separates the operating points into feasible and infeasible regions. The calculation method to obtain the predicted collapsing point can be illustrated in Fig.5.

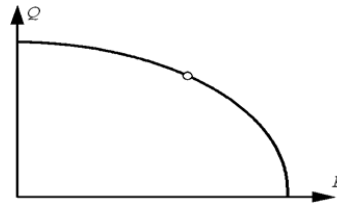

Figure 5. The predicted collapsing point calculation.

E. Test System

Fig. 6 shows the simplified diagram of test system. It has 20 buses operating at the voltage of 12.47 kV, 19 circuits/transformers, and the hypothetical wind power is connected at bus 20 at 0.69 kV. The detailed of the system is not showed but it has only one circuit of 138 kV [4]. The power wind farm is a variable speed direct drive synchronous generator connected to the Point of Common Coupling, (PCC) by a full-load converter. It can be represented by a P-Q bus or a P-V bus, since it has the capacity to control the reactive power. The loads are distributed considering the thermal limits of the conductors. The line parameters, loads and Generator data are shown in Tables I. The load is increased with steps of 0.5% in all loads, starting from a normal operating point. The limits of the safe voltage in distribution buses are 0.95 to 1.05 per unit. The system was simulated considering two different scenarios.

TABLE I . LINE PARAMETERS OF DISTRIBUTION SYSTEM IN PER UNIT ON 40 MVA BASE.

	From	To	Resistance	Reactance
1	1	2	0.1196	0.1263
2	2	3	0.125	0.1505
3	2	9	0.0713	0.0185
4	2	10	0.0664	0.0702
5	3	4	0.0936	0.1129
6	3	5	0.6294	0.7586
7	5	6	0.3123	0.3766
8	5	7	0.624	0.4947
9	5	8	0.6559	0.5201
10	10	11	0.0561	0.0592
11	10	16	0.0859	0.0908
12	11	12	0.0471	0.0496
13	11	15	0.037	0.0095
14	12	13	0.08	0.0844
15	12	14	0.0257	0.0067
16	16	17	0.0229	0.0059
17	16	18	0.0286	0.0075

18	19	1	0	0.28
19	20	12	0	0.28

First: the wind power generation is connected and operates as a P-Q bus with unit power factor. His particular operating point for actual operation state is $P_G = 7.5$ MW and $Q_G = 0.0$ MVAR. The Wind Power can also be represented by a P-V bus with the reactive power limits, so that when the limits are reached, it becomes a P-Q bus. In modern wind turbine system it is possible to control the power factor, provides in this way, an additional source of reactive to help the power systems to control de voltage.

Second: without Wind Power Generation.

Fig. 7, 8 show the first scenario and the second for the load buses 13 of the system.

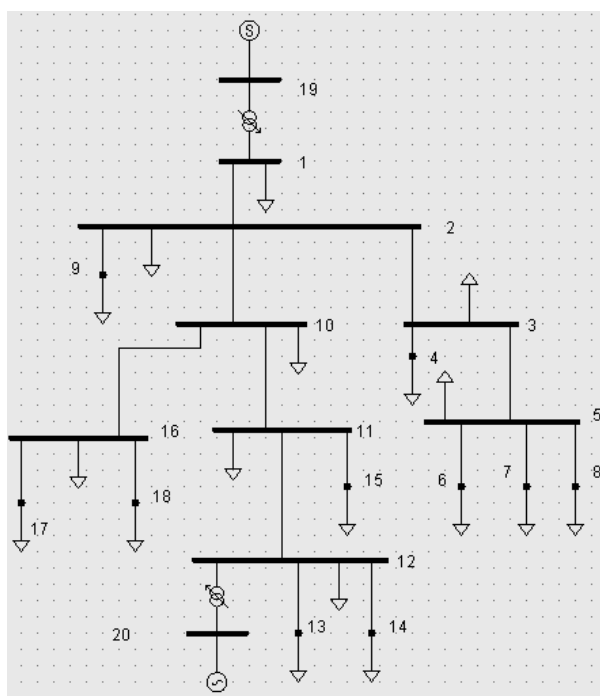

Figure 6. Distribution Power System Test.

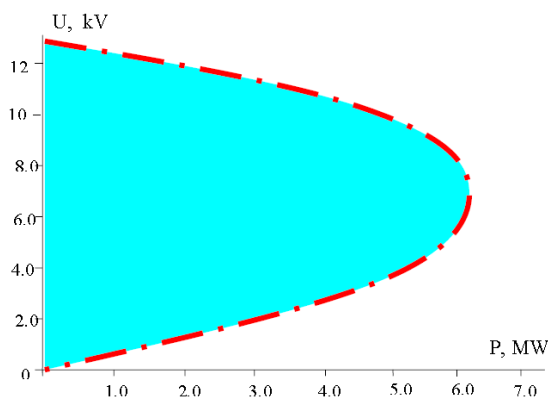

Figure 7. Loading in bus 13 - Voltage stability region with the contribution of wind power.

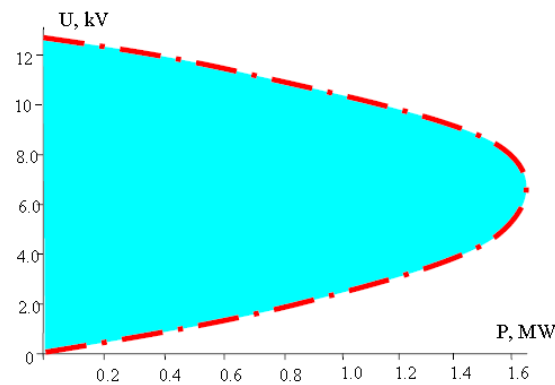

Figure 8. Loading in bus 13 - Voltage stability region without wind power.

Figure 9.

4. Conclusion

A very efficient method is presented to determine the maximum permissible load that can be allowed in each bus of a distribution power system. To ensure the reliability of the results, a comparison between the proposed and a previous analytical method is carried out in a simple two bus system connected by a single transmission line. The results are very close and the proposed method was applied on a distribution power system. The presence of wind power is considered in order to analyze the effect of this generation on voltage operation and at the voltage stability limits. The voltage stability limit region and a sub-region in which the voltages at the bus are in acceptable ranges are defined for different power factors. For practical purposes, the PQ curves can be useful to determine the capacity of certain buses of the system to support an increasing in the load demand. Of course, to meet de new demand, the limits of secure voltages must be determined. P-Q curves can help the utilities in the choice the best point to connect the wind farms.

5. References

- [1] P.Kundur: Power: System Stability and Control, New York: McGraw-Hill, 1994.
- [2] Ake Anderson; Power quality of wind turbines; Thesis Degree of Doctor of Philosophi; Chalmers Unversity of Technology; Goteborg Swedent 2000.
- [3] Fritz W. Mohn, C. Zambroni de Souza: Tracing PV and QV Curves with the Help of a CRIC Continuation Method, IEEE Trans. on Power Systems, Vol. 21, N° 3, pp.1115- 1122, 2006.
- [4] McGraw-Edison Company, Power System Division: Distribution-System Protection Manual.
- [5] M. Chinchilla, S. Arnalte, J.C. Burgos, and J.L. Rodríguez: Power limits of grid-connected modern wind energy systems, Renewable Energy, September 2005, pp. 1455-1470.
- [6] Richard Piwko, Nicholas Miller, Juan Sanchez Gasca, Xiaoming Yuan, Renchang Dai, James Lyons; Integrating Large Wind Farms into Weak Power Grids with Long Transmission Lines; IEEE/PES Transmission and Distribution Conference & Exhibition, China, 2005. 0 2.0 4.0 6.0 8.0 10 0.4 12 0.6 0.8 1.0 1.2 0.2 1.41.6P, MW U, kV
- [7] L. S. Barros, W. S. Mota, D. F. P. Moura; Matrix Method to Linearization and State Space Representation of Power Systems Containing Doubly Fed Induction Machines Operating as Wind Generators; 2006 IEEE PES Transmission and Distribution Conference and Exposition Latin America, Venezuela.
- [8] Poul Sørensen, Anca Hansen, Lorand Janosi, John Bech, Birgitte Bak-Jensen; Simulation of Interaction between Wind Farm and Power System; Risø National Laboratory, Roskilde December 2001.